

On This Page:

The 804 Cornice and various Balmer plaster columns, pilasters and custom arches. Note the concave radial casting of the 804 in the room corner.

Photo courtesy of Allan Greenberg, Architect.

Plaster Cornices & Friezes



Gypsum Plaster Cornice Mouldings

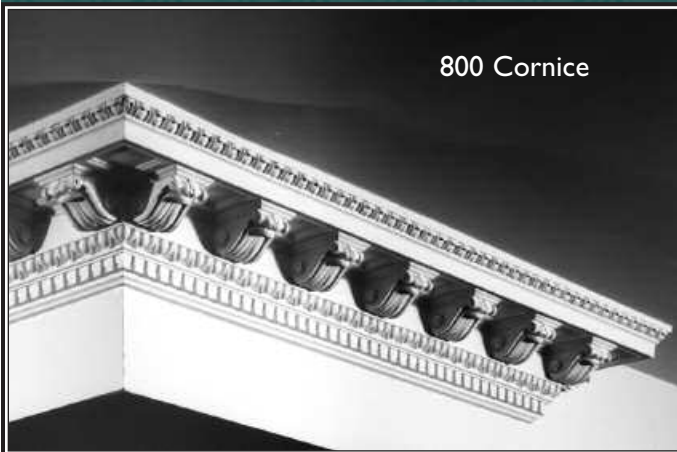

Contemporary Profile Plaster Cornice Mouldings

8905

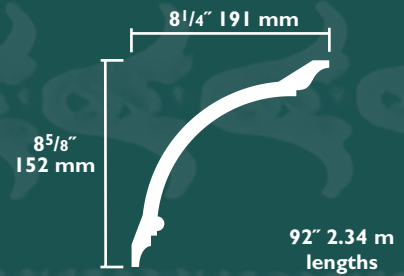
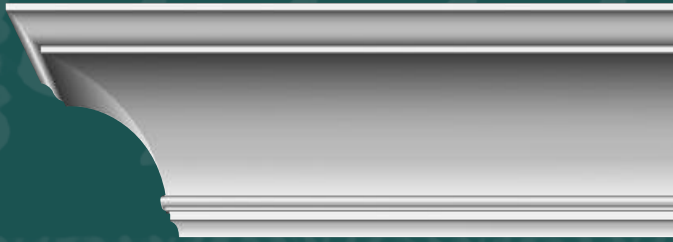

8904

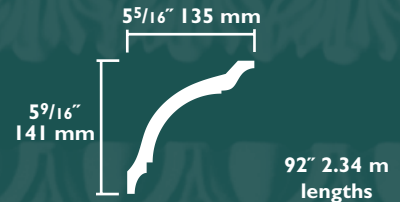

887



8901

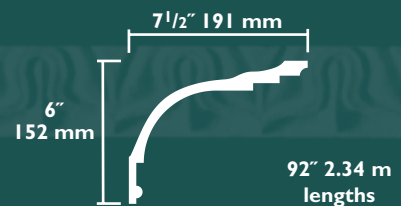

8902

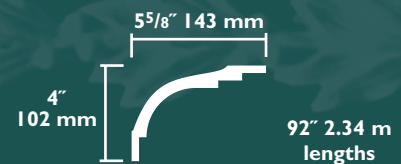

8907

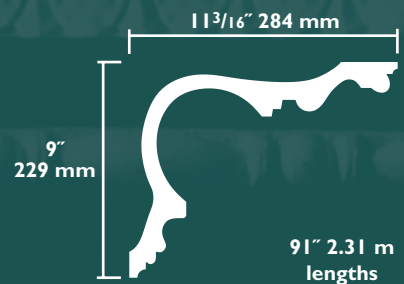
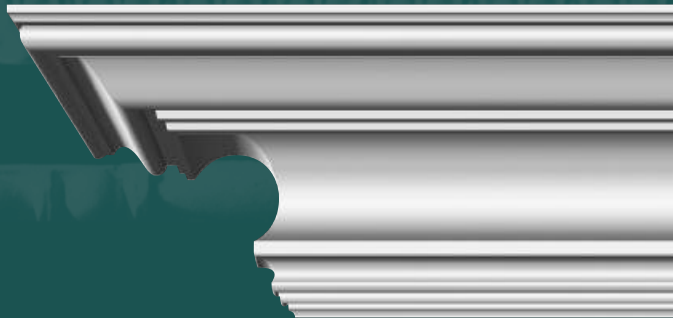

In addition to the profiles shown here, Balmer can supply any plain run profile you require.

Cornices marked with the symbol **L.T.** ✓ can be ordered specially manufactured for use as a light trough (using miniature lighting systems) at extra cost. Add the letters **LT** to the product number when ordering.

Contemporary Profile Plaster Cornice Mouldings

8906

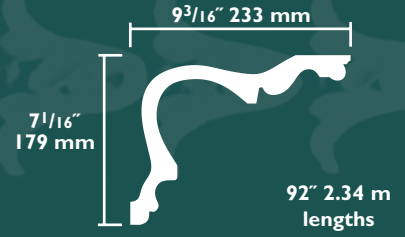

845

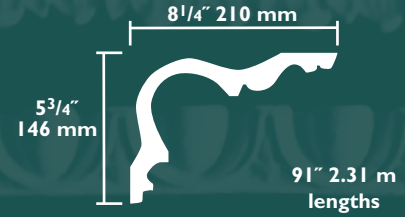

845A

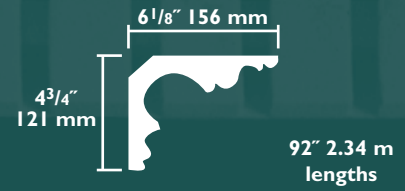

847

L.T. ✓

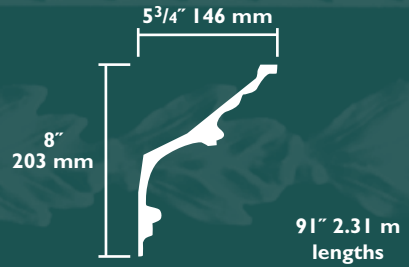

847A

L.T. ✓



843



Contemporary Profile Plaster Cornice Mouldings

833



815

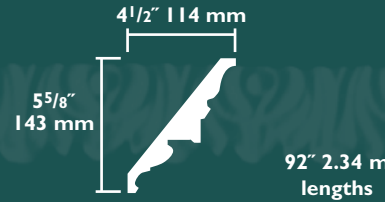

8903

L.T. ✓

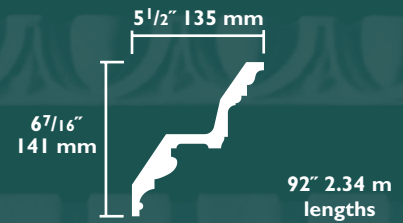

8908

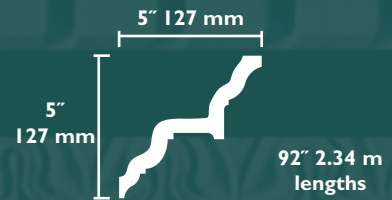
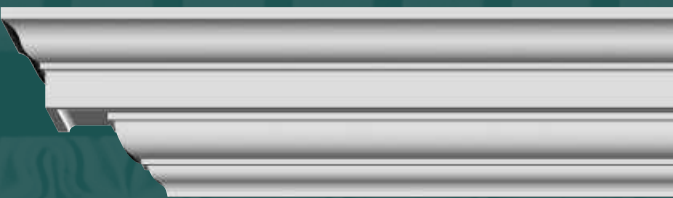

8909

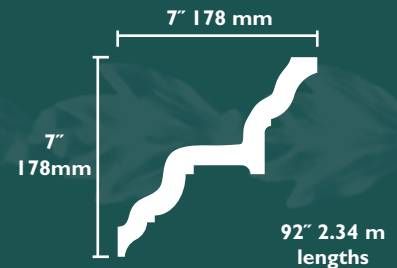

8910

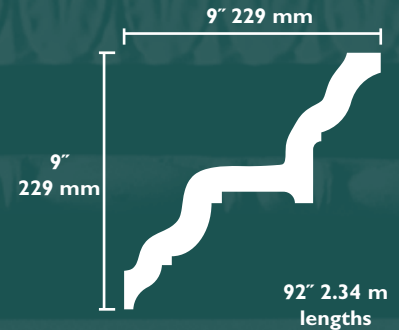
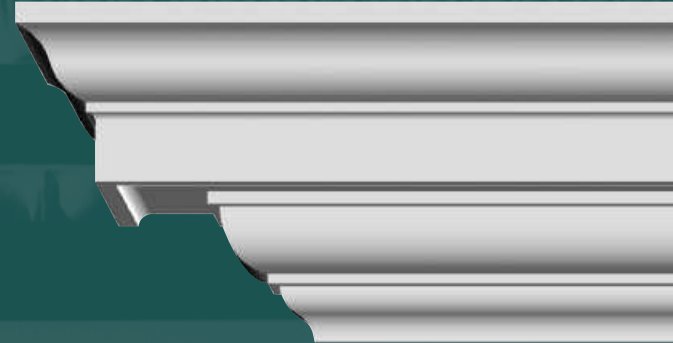

In addition to the profiles shown here, Balmer can supply any plain run profile you require.

Cornices marked with the symbol L.T. ✓ can be ordered specially manufactured for use as a light trough (using miniature lighting systems) at extra cost. Add the letters **LT** to the product number when ordering.

Classical, Enriched Plaster Cornice Mouldings



809

809



Repeat: 2³/₄" 70 mm



812

L.T. ✓



Repeat: 2⁵/₁₆" 59 mm

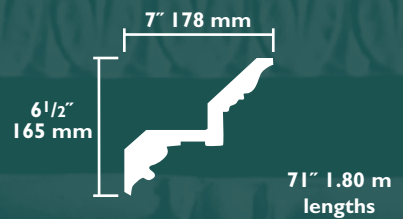

823

L.T. ✓



Repeat: 18⁷/₁₆" 479 mm

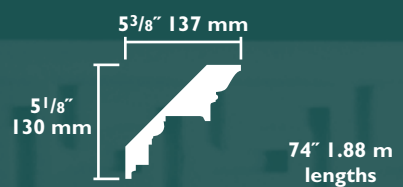

Classical, Enriched Plaster Cornice Mouldings

860

L.T. ✓



Repeat: 4⁵/₈" 117 mm

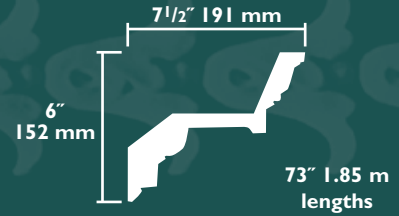

818

L.T. ✓



Repeat: 1³/₈" 35 mm

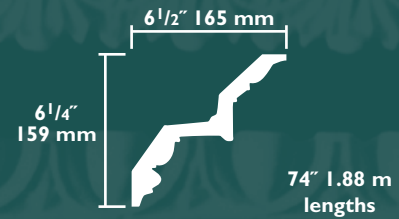

871



Repeat: 1⁷/₁₆" 37 mm

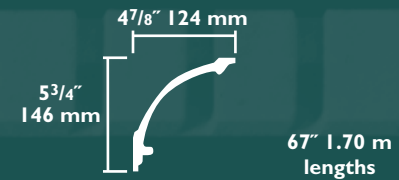

911



Repeat: 2" 51 mm

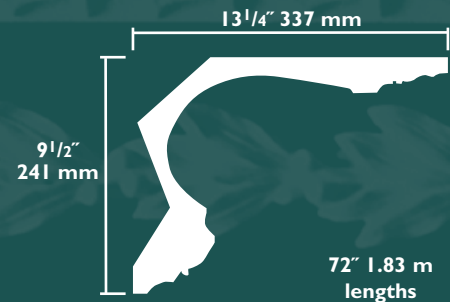

8804



Repeat: 12" 305 mm

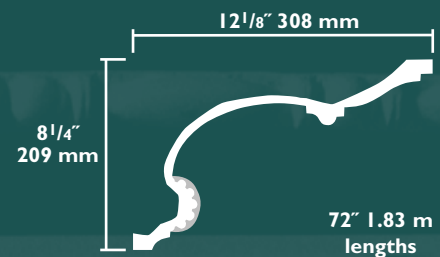

Cornices marked with the symbol **L.T. ✓** can be ordered specially manufactured for use as a light trough (using miniature lighting systems) at extra cost. Add the letters **LT** to the product number when ordering.

Classical, Enriched Plaster Cornice Mouldings

813

L.T. ✓



Repeat: 1/2" 13 mm

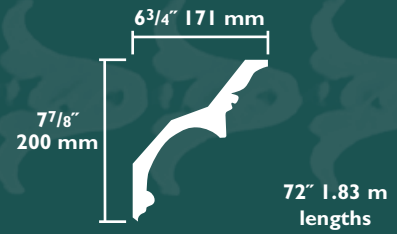

798



Repeat: 1" 25 mm

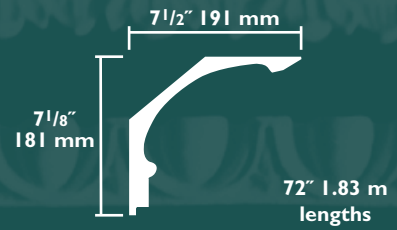

805

L.T. ✓



Repeat: 7⁵/₈" 194 mm

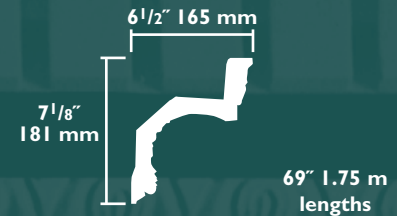

895

L.T. ✓



Repeat: 36" 914 mm

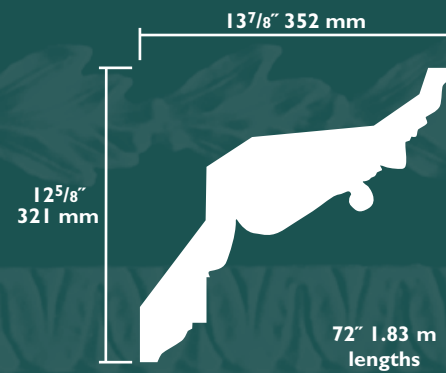

806

L.T. ✓



Repeat: 5³/₈" 137 mm

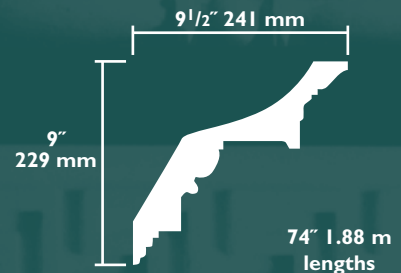

Classical, Enriched Plaster Cornice Mouldings

821

L.T. ✓



Repeat: 14 1/2" 368 mm

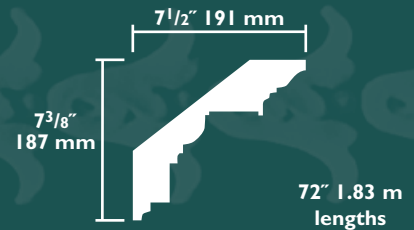

800

L.T. ✓



Repeat: 6 13/16" 173 mm

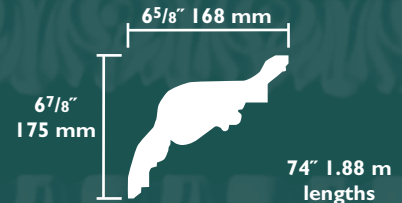

816

L.T. ✓



Repeat: 6 1/8" 156 mm

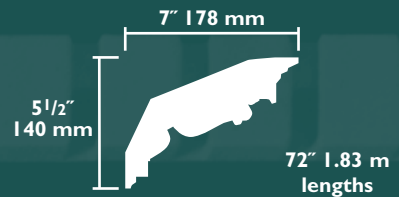

899

L.T. ✓



Repeat: 3" 76 mm

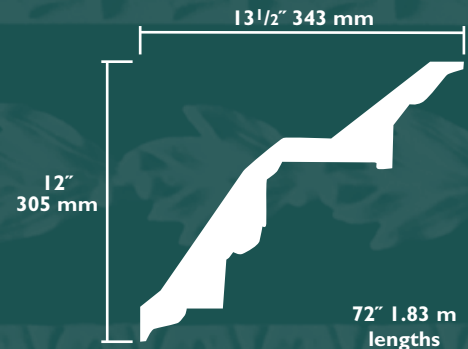

898



Repeat: 15" 381 mm

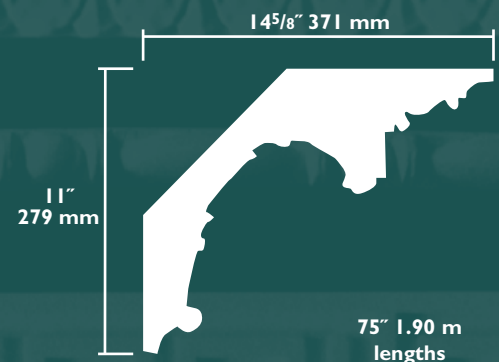

Cornices marked with the symbol L.T. ✓ can be ordered specially manufactured for use as a light trough (using miniature lighting systems) at extra cost. Add the letters LT to the product number when ordering.

Classical, Enriched Plaster Cornice Mouldings

804

L.T. ✓



Repeat: 10¹/₈" 257 mm

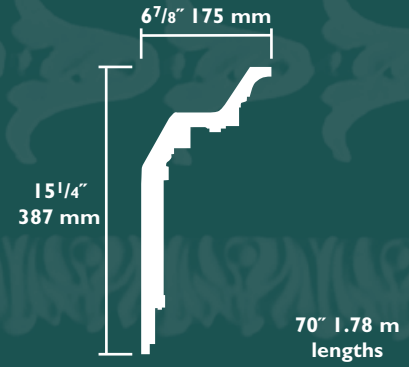

784

L.T. ✓



Repeat: 3⁵/₁₆" 84 mm

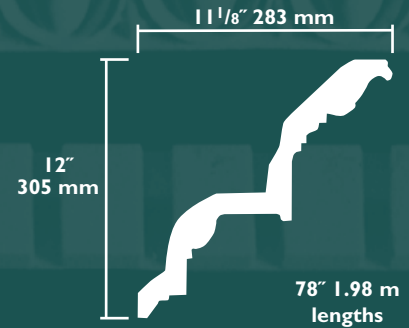

896



Repeat: 11¹/₂" 292 mm

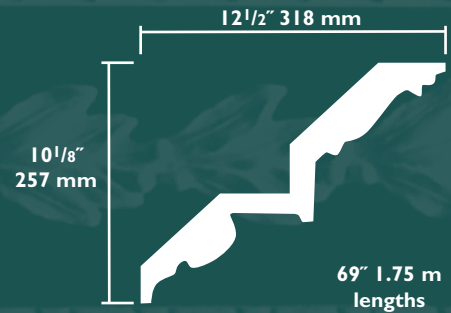

897



Repeat: 5¹/₁₆" 144 mm

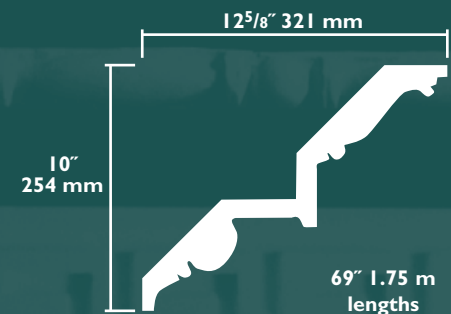

Classical, Enriched Plaster Cornice Mouldings

857

L.T. ✓



Repeat: $8\frac{3}{8}$ " 213 mm

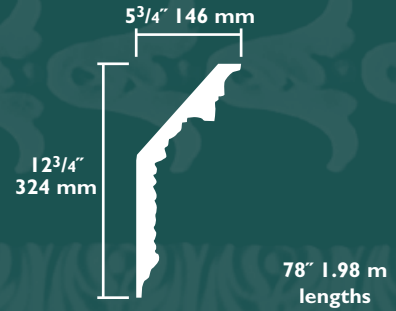

858



Repeat: 3" 76 mm

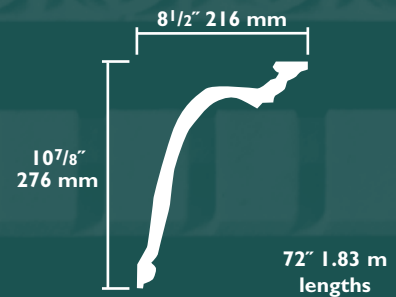

801



Repeat: $12\frac{1}{8}$ " 327 mm

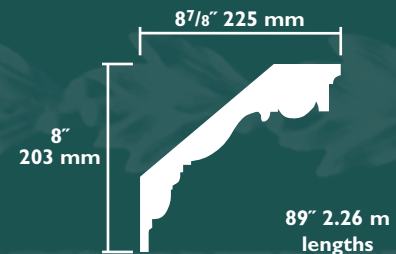

822



Repeat: 4" 102 mm

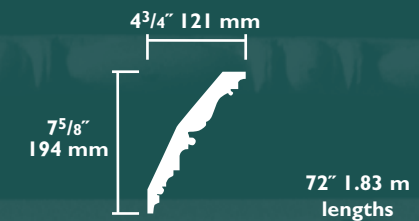

Cornices marked with the symbol L.T. ✓ can be ordered specially manufactured for use as a light trough (using miniature lighting systems) at extra cost. Add the letters **LT** to the product number when ordering.

Classical, Enriched Plaster Cornice Mouldings

832

L.T. ✓



Repeat: $1\frac{5}{16}$ " 24 mm

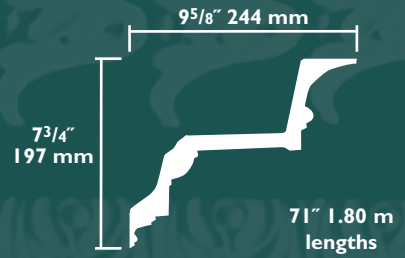

874



Repeat: $1\frac{5}{16}$ " 33 mm

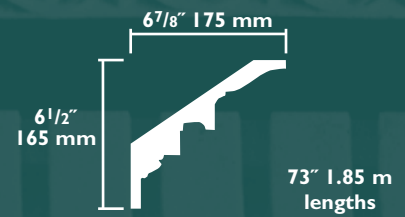

888



Repeat: $2\frac{1}{8}$ " 54 mm

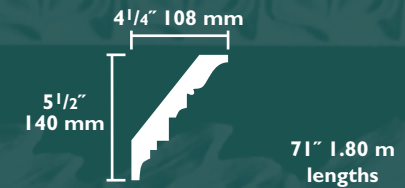

885



Repeat: $\frac{7}{16}$ " 22 mm

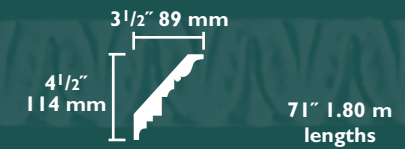

849



Repeat: $1\frac{5}{16}$ " 24 mm

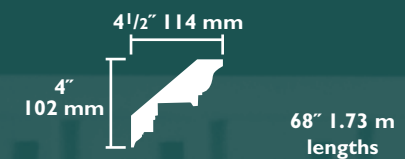

Classical, Enriched Plaster Cornice Mouldings

8803

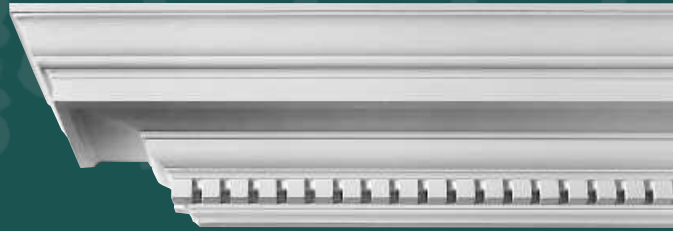

Repeat: 1 1/4" 32 mm

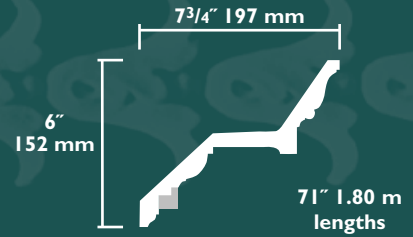

8802

L.T. ✓

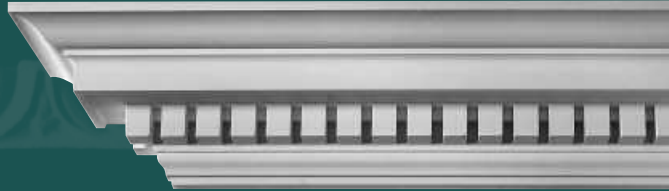

Repeat: 1 1/2" 38 mm

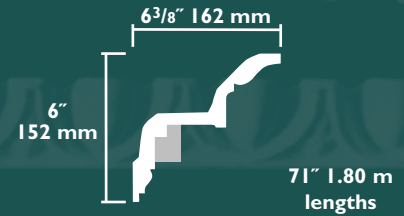

8801

L.T. ✓



Repeat: 1 1/2" 38 mm

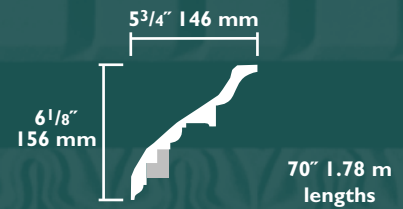

8806



Repeat: 13 1/8" 333 mm

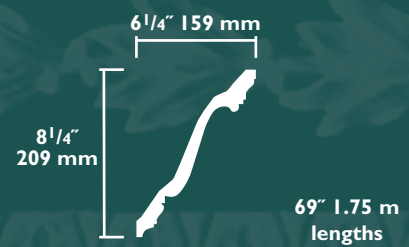

8807



Repeat: 1" 25 mm

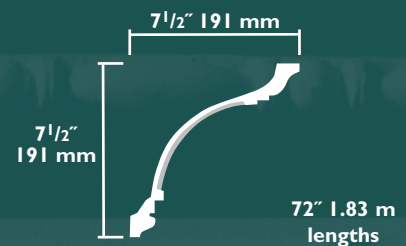

Cornices marked with the symbol **L.T. ✓** can be ordered specially manufactured for use as a light trough (using miniature lighting systems) at extra cost. Add the letters **LT** to the product number when ordering.

Classical, Enriched Plaster Cornice Mouldings

8809

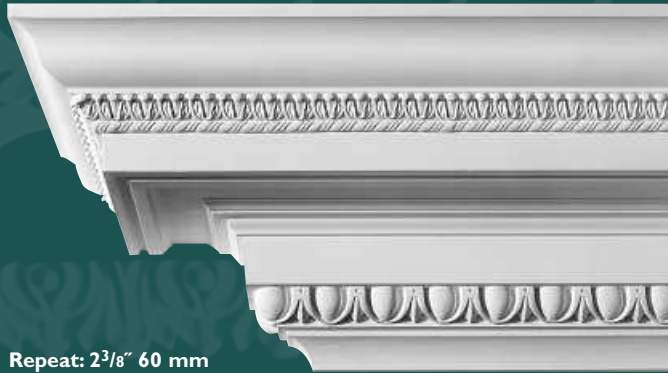

Repeat: $2\frac{3}{8}$ " 60 mm

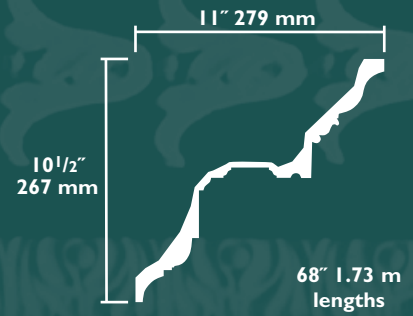

905



Repeat: 12" 305 mm

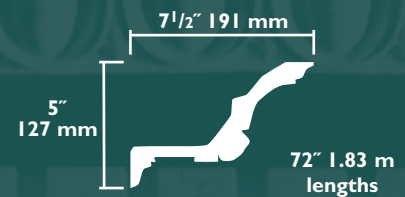

811



Repeat: 18" 457 mm

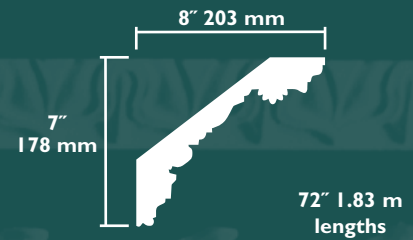

802



Repeat: $10\frac{1}{8}$ " 257 mm

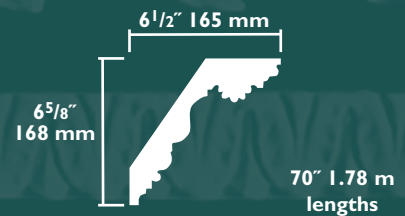

810

L.T. ✓



Repeat: $1\frac{1}{16}$ " 43 mm

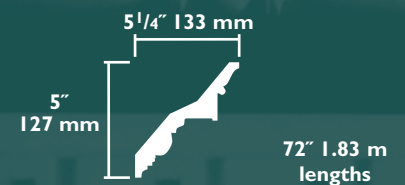

Classical, Enriched Plaster Cornice Mouldings

848



Repeat: 16" 406 mm



852



Repeat: 1 3/8" 41 mm

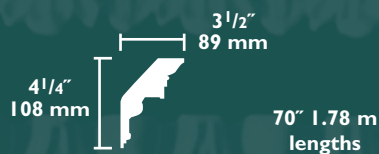

886



Repeat: 3 1/2" 89 mm



853



Repeat: 2 1/2" 64 mm

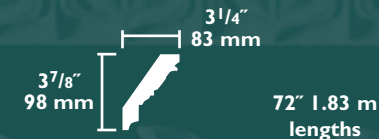

8810



Repeat: 1 3/16" 30 mm

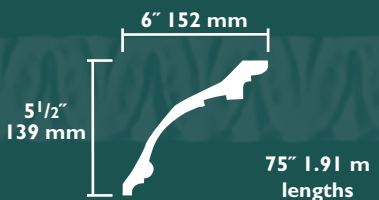

8811



Repeat: 3" 76 mm

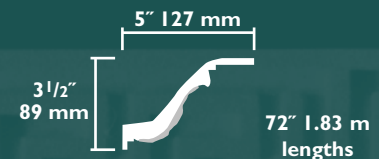

Builder's Line Plaster Cornice Mouldings

BL100



Repeat: 1 1/4" 32 mm

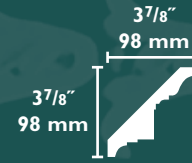

91" 2.31 m lengths

BL200

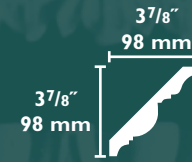

92" 2.34 m lengths

BL300



Repeat: 1 5/8" 41 mm

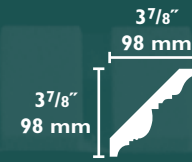

91" 2.31 m lengths

BL400



Repeat: 1 1/4" 32 mm

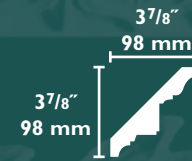

90" 2.29 m lengths

BL500



Repeat: 2 1/8" 56 mm

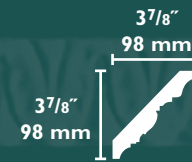

90" 2.29 m lengths

BL700



94" 2.4 m lengths

Frieze Style Plaster Cornice Mouldings

901



Repeat: 10¹/₈" 257 mm

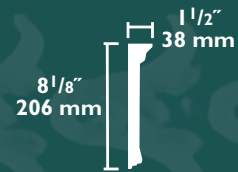

81" 2.06 m lengths

838



Repeat: 28⁷/₈" 733 mm

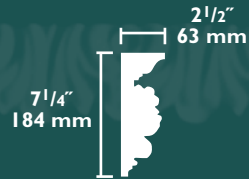

86" 2.18 m lengths

882



Repeat: 18¹/₂" 470 mm

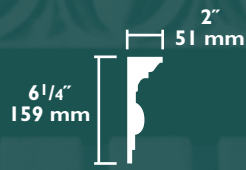

92" 2.34 m lengths

875



Repeat: 2³/₈" 60 mm

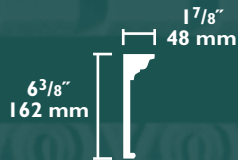

74" 1.88 m lengths

8805



Repeat: 8" 203 mm

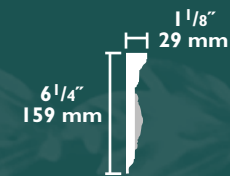

80" 2.03 m lengths

2151



Repeat: 3¹/₈" 79 mm



72" 1.83 m lengths

884



Repeat: 19" 483 mm



57" 1.45 m lengths

869



Repeat: 3/4" 19 mm

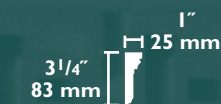

54" 1.37 m lengths

Gypsum Plaster Covens & Light Troughs

Radial 90 Degree Covens

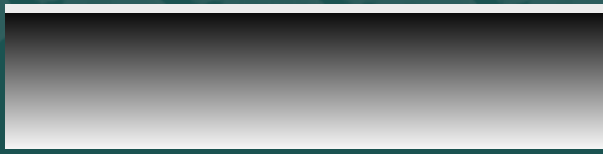

Coves are supplied in 92" (2.34 m) lengths

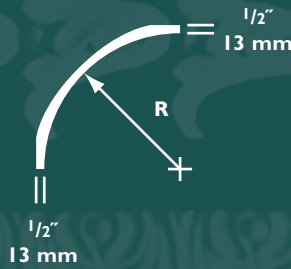

Number	R	
	inch	mm
3901a	4	102
3901b	6	152
3901c	8	203
3901d	10	254
3901e	12	305



Light Trough

Cornices marked with the symbol **L.T.** ✓ on the preceding pages can be ordered specially manufactured for use as a light trough (using miniature lighting systems) at extra cost. The letters **LT** must be added to the product number when ordering.

A diagram of a light trough is shown at the left. The addition of a cove above the light trough, as shown at the right, enhances an indirect lighting design. The cove can be mounted so that its inner surface is flush with the ceiling as shown or it may be mounted beneath the ceiling. Lighting systems can be mounted either on the wall or on the light trough.

In addition to the **LT** versions of standard cornices, we offer the two designs shown below which are suited for use as light troughs using standard fluorescent tube lighting systems.



Light Trough & Cove

Light Troughs for use with Standard Fluorescent Lighting Systems

3902

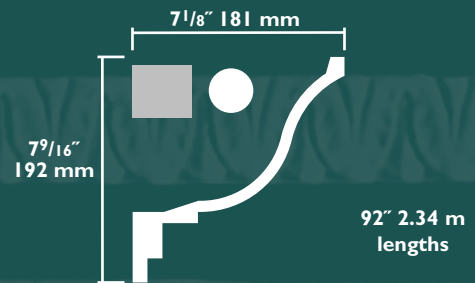

3903

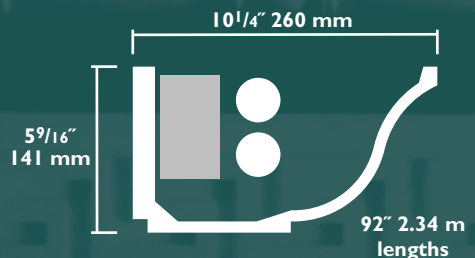
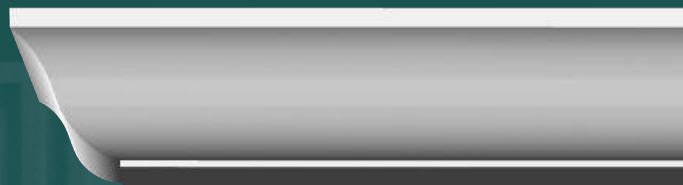

Gypsum Plaster Friezes

8918



8921



8922

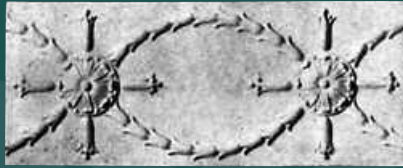

1456



8917



640



1524



1520



1431



8916

Gypsum Plaster Friezes



1439



1372



1434



1552



1455



8920

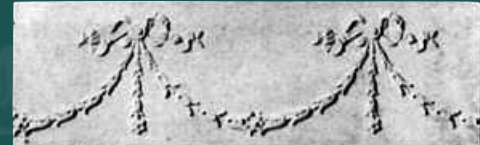

1436



8919



1550



1378



588



1202



1433

Number	Height		Length		Projection		Number	Height		Length		Projection	
	inch	mm	inch	mm	inch	mm		inch	mm	inch	mm	inch	mm
588	8 1/2	216	42	1067	7/8	22	1456	10 3/4	273	31	787	3/8	10
640	6 5/8	168	80	2032	1/8	3	1520	15 1/2	394	60	1524	1/4	6
1202	4 5/8	118	58	1473	1/2	13	1524	18 3/8	467	78 1/2	2013	5/8	16
1372	14 5/8	371	63	1600	1/4	6	1550	5 1/2	140	48	1219	3	76
1378	7 5/8	194	36	914	1/2	13	1552	9 5/8	245	71	1803	1/4	6
1431	21 1/8	537	51 1/4	1302	3/8	10	8916	10 1/2	267	90 1/4	2292	3/4	19
1433	6 3/8	162	44	1118	1/8	3	8917	12	305	92 1/2	2350	1 1/2	38
1434	14	356	72 3/4	1848	2	51	8918	16 1/4	413	71 1/4	1810	2	51
1436	9 1/4	235	45	1143	1/8	3	8919	7 1/4	184	72	1829	3/4	19
1439	16	406	48	1219	3/8	10	8920	8	203	70 1/2	1791	1/2	13
1455	11 1/4	286	65 1/2	1664	1/4	6	8921	10 1/2	267	69 1/2	1765	1 1/4	32
							8922	10 1/2	267	70	1778	1 1/4	32

Gypsum Plaster Friezes



1548



1373



1388



1531



1389



1549



347



375



1379



1488



1545



620



1390



1529



1588



1435



1496



2769A



1530



1343



1149

Gypsum Plaster Friezes



1551



1513



1512



1471



402



1352



1365



1407



1794

Number	Height		Length		Projection		Number	Height		Length		Projection	
	inch	mm	inch	mm	inch	mm		inch	mm	inch	mm	inch	mm
347	11 1/2	292	34	864	3/8	10	1471	8 7/8	225	38	965	1/2	13
375	11	279	36 1/4	921	3/8	10	1488	4 3/4	146	24 1/2	622	1	25
402	11	279	46	1168	1 1/4	32	1496	8	203	49	1245	1/4	6
620	6 3/4	171	72	1829	3/4	19	1512	11 7/8	302	64	1626	3/8	10
1149	3 3/4	70	26	660	1	25	1513	16	406	58 1/2	1486	3/4	19
1343	4	102	41	1041	7/8	22	1529	9 1/4	235	53	1346	1	25
1352	11 7/8	302	51	1295	3/8	10	1530	5 1/4	133	63	1600	1 1/4	32
1365	11 1/4	286	56	1422	1	25	1531	12	305	60	1524	1 1/8	29
1373	6	152	24	610	1/2	13	1545	6 3/4	171	35 1/2	902	1/4	6
1379	7 7/8	175	35	889	3/8	10	1548	10 1/4	260	27 1/2	686	1/2	13
1388	6 3/4	171	48	1219	1/2	13	1549	12 5/8	321	66	1676	3/4	19
1389	7 7/8	200	73	1854	7/8	22	1551	9	229	24	610	1/2	13
1390	8	203	55	1397	1 5/8	41	1588	7	178	63	1600	1 1/8	29
1407	14 1/2	368	26	660	1 1/2	38	1794	12	305	45	1143	7/8	22
1435	7 7/8	200	43 1/4	1099	1/8	3	2769A	7 1/4	184	57	1448	5/8	16

Gypsum Plaster Friezes



1302



1304



1406



389



683



1356



1800



1526

Number	Height		Length		Projection		Number	Height		Length		Projection	
	inch	mm	inch	mm	inch	mm		inch	mm	inch	mm	inch	mm
389	10 1/4	260	34 1/2	876	3/8	10	1356	12 5/8	321	54	1372	1/2	13
683	9	229	38 1/2	978	1	25	1406	10 3/8	264	43	1143	7/8	22
1302	13 1/4	337	71 1/2	1816	1/2	13	1526	13 7/8	352	70	1778	3/8	10
1304	9 1/8	232	51	1295	1	25	1800	13 1/4	337	71 1/2	1816	1 1/2	38

Gypsum Plaster Friezes



1314



1321



1315



1322



1316



1323



1318



1325



1324



604



621



638

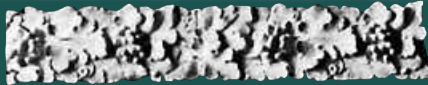

1398



1527



929



1400



1341



1517



1430



1528



1586



952



672



313



1446



1364

Number	Height		Length		Projection		Number	Height		Length		Projection	
	inch	mm	inch	mm	inch	mm		inch	mm	inch	mm	inch	mm
313	4 1/2	114	32	813	5/8	16	1323	5 1/8	130	34	864	3/8	10
604	5	127	53	1346	3/8	10	1324	5 3/8	137	60	1524	1/2	13
621	3	76	39	991	1/2	13	1325	3	76	42	1067	1/4	6
638	6 5/8	168	40	1016	3/8	10	1341	3 3/4	70	48	1219	1/2	13
672	3 1/2	89	39	991	3/4	19	1364	2 5/8	67	46	1168	5/8	16
929	3 7/8	73	22	559	1/2	13	1398	5	127	32	813	5/8	16
952	4	102	36	914	1/2	13	1400	3 7/8	73	28	711	3/4	19
1314	7	178	45	1143	1/4	6	1430	5 5/8	143	69	1753	3/4	19
1315	5 1/2	140	30	762	1/2	13	1446	5	127	48	1219	1/4	6
1316	6 3/8	162	53	1346	1/4	6	1517	6 1/2	165	71	1803	3/8	10
1318	5	127	25	635	1/2	13	1527	2 1/2	64	41	1041	5/8	16
1321	5	127	32	813	1/4	6	1528	3 1/2	89	28	711	1 1/8	29
1322	5 1/2	140	55	1397	3/8	10	1586	5	127	49	1245	3/8	10

Gypsum Plaster Friezes

1303



1312



1319

1438



1313



1320

1305



1309



1306



1310



1311



1344



1345



1340



1470

Number	Height		Length		Projection		Number	Height		Length		Projection	
	inch	mm	inch	mm	inch	mm		inch	mm	inch	mm	inch	mm
1303	12	305	60 ¹ / ₂	1537	¹ / ₂	13	1319	10 ¹ / ₄	260	70	1778	³ / ₈	10
1305	7	177	51	1295	⁵ / ₈	16	1320	8 ⁷ / ₈	225	50	1270	¹ / ₄	6
1306	6 ¹ / ₂	165	36	914	¹ / ₂	13	1340	4	102	32	813	¹ / ₄	6
1309	8 ¹ / ₈	206	30	762	⁵ / ₈	16	1344	4 ⁵ / ₈	118	43	1092	³ / ₈	10
1310	6 ¹ / ₈	156	33	838	¹ / ₂	13	1345	9 ¹ / ₂	241	40	1016	³ / ₈	10
1311	7	178	76	1930	³ / ₄	19	1438	9	229	60	1524	¹ / ₂	13
1312	12 ¹ / ₂	318	80	2032	1	25	1470	3 ³ / ₄	95	46	1168	³ / ₈	10
1313	7 ¹ / ₄	184	38	965	⁵ / ₈	16							

Gypsum Plaster Friezes & Panels



1546



1521



1543



1792



1536



8923



444



1544

Number	Height		Length		Projection		Number	Height		Length		Projection	
	inch	mm	inch	mm	inch	mm		inch	mm	inch	mm	inch	mm
444	17 ⁷ / ₈	454	34 ⁷ / ₈	886	3 ¹ / ₄	19	1544	15 ³ / ₄	400	33 ⁵ / ₈	854	3 ¹ / ₄	19
1521	14 ¹ / ₈	359	38	965	5 ¹ / ₈	16	1546	13 ⁷ / ₈	352	71 ¹ / ₂	1816	3 ¹ / ₈	19
1536	16 ⁷ / ₈	429	16 ⁷ / ₈	429	1	25	1792	16 ¹ / ₄	413	46	1168	3 ¹ / ₄	19
1543	13	330	43 ³ / ₄	1111	3 ¹ / ₄	19	8923	20	508	42 ¹ / ₄	1073	1	25

Gypsum Plaster Panels



2897

Number	Width		Height		Projection	
	inch	mm	inch	mm	inch	mm
2383	47	1194	22	559	3 1/8	79
2858	53 1/4	1353	40 1/4	1022	1	25
2896	18	457	36	914	1 1/4	32
2897	18	457	36	914	1 1/4	32



2896

2858



2383 **DaVinci's Last Supper** - This panel is designed to be recessed into the wall 3 1/8" (79 mm) with the frame moulding flush with the wall face. The required recess opening is 19 3/4" X 44 5/8" (502 X 1133 mm).

On This Page:
The 233 ceiling center

Gypsum Plaster Ceiling Centers, Swags & Rosettes



Gypsum Plaster Ceiling Centers



270 Diam 16" 406 mm
Proj 3/4" 19 mm



293 Diam 12" 305 mm
Proj 5/8" 16 mm



227 Diam 11 1/4" 286 mm
Proj 1" 25 mm



229 Diam 14" 356 mm
Proj 1 3/8" 34.9 mm



214 Diam 21" 533 mm
Proj 1 1/2" 38 mm



267 Diam 21 1/2" 546 mm
Proj 3/4" 19 mm



251 Diam 17 1/2" 445 mm
Proj 2 1/4" 57 mm



226 Diam 23 1/4" 591 mm
Proj 1" 25 mm



240 Diam 24" 610 mm
Proj 1 1/4" 32 mm



205 Diam 24" 610 mm
Proj 1 3/4" 44 mm



215 Diam 28 1/2" 724 mm
Proj 1 5/8" 41 mm



202 Diam 27 1/2" 699 mm
Proj 3/4" 19 mm

Gypsum Plaster Ceiling Centers



274 Diam 30" 762 mm
Proj 1 3/4" 44 mm



243 Diam 30" 762 mm
Proj 1 3/8" 35 mm



297 Diam 36" 914 mm
Proj 2 1/2" 64 mm



210 Diam 33" 838 mm
Proj 1" 25 mm



260 Diam 23" 584 mm
Proj 2 1/4" 57 mm



298 Diam 31" 787 mm
Proj 2 1/4" 57 mm

Gypsum Plaster Ceiling Centers



275 Diam 28" 711 mm
Proj 2" 51 mm



232 Diam 60 1/2" 1.537 m
Proj 1 1/2" 38 mm
Supplied in 4 quarters



291 32 × 22" 813 × 559 mm
Proj 3/4" 19 mm

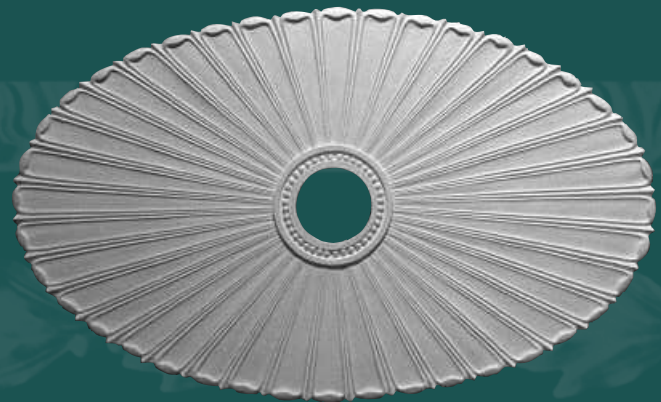

281 32 × 19" 813 × 483 mm
Proj 3/4" 19 mm



248 75 × 43" 1.905 × 1.092 m
Proj 1 1/4" 32 mm
Supplied in 2 halves



247 90 × 57" 2.286 × 1.448 m
Proj 1 1/4" 32 mm
Supplied in 2 halves

Gypsum Plaster Ceiling Centers



287 Diam 34" 864 mm
Proj 3/4" 19 mm



276 Diam 35" 889 mm
Proj 1 1/2" 38 mm



218 Diam 24" 610 mm
Proj 1 1/2" 38 mm

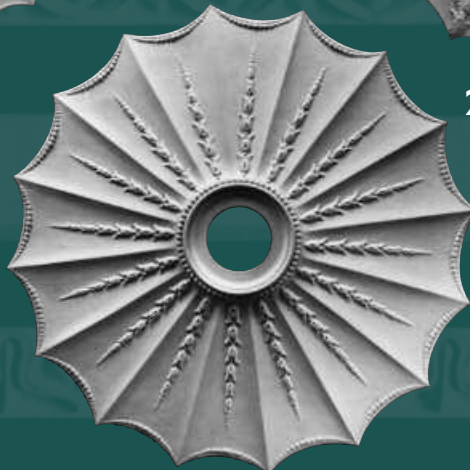

233 Diam 27" 686 mm
Proj 1 3/8" 35 mm



236NH 21 × 13 1/4" 533 × 337 mm
Proj 5/8" 16 mm



977 Diam 48" 1.219 m
Proj 1" 25 mm

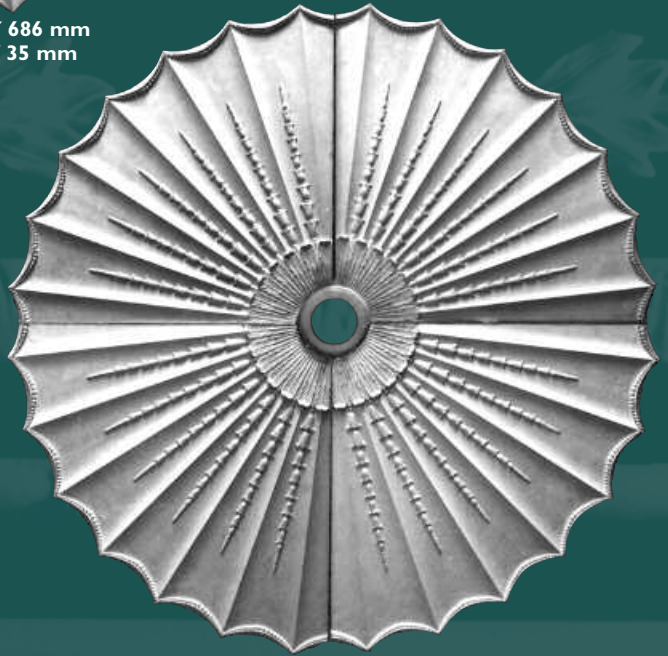

268 Diam 96" 2.438 m
Proj 1 3/8" 35 mm

269 Diam 60" 1.524 m
Proj 1 1/4" 32 mm

Both Supplied in 4 quarters

Gypsum Plaster Ceiling Centers



207 Diam 38 1/2" 978 mm
Proj 1 3/8" 35 mm
Supplied c/w 8 #323 swags



238 Diam 37 1/2" 953 mm
Proj 1 3/8" 35 mm
Supplied c/w 8 #3336 swags

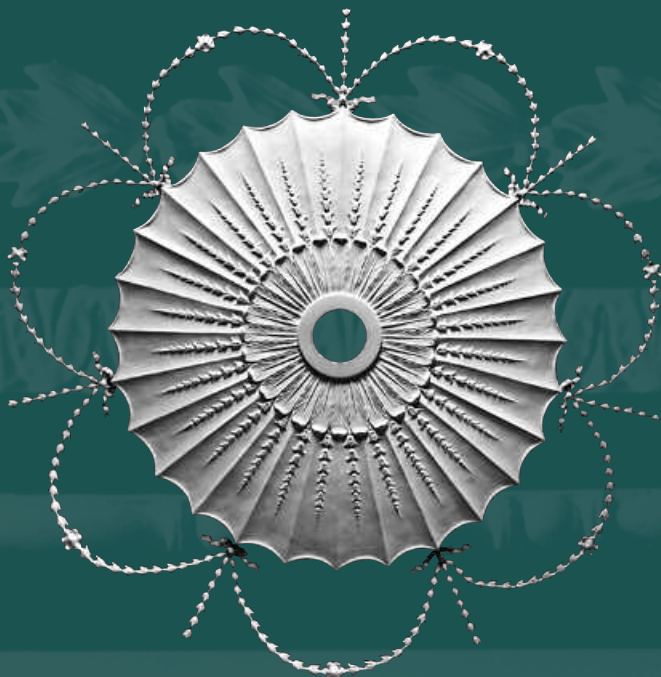

912 Diam 49" 1.245 m
Proj 3/4" 19 mm
Supplied c/w 7 #3354 swags



Four or more swags can be used alone to create a filigree center unit.

Gypsum Plaster Ceiling Centers

1781

Large Oval Adams Center
81 1/2" × 50" 2.070 × 1.270 m
(assembled)
Proj 5/8" 15.9 mm
Supplied in 2 halves
(one half shown)

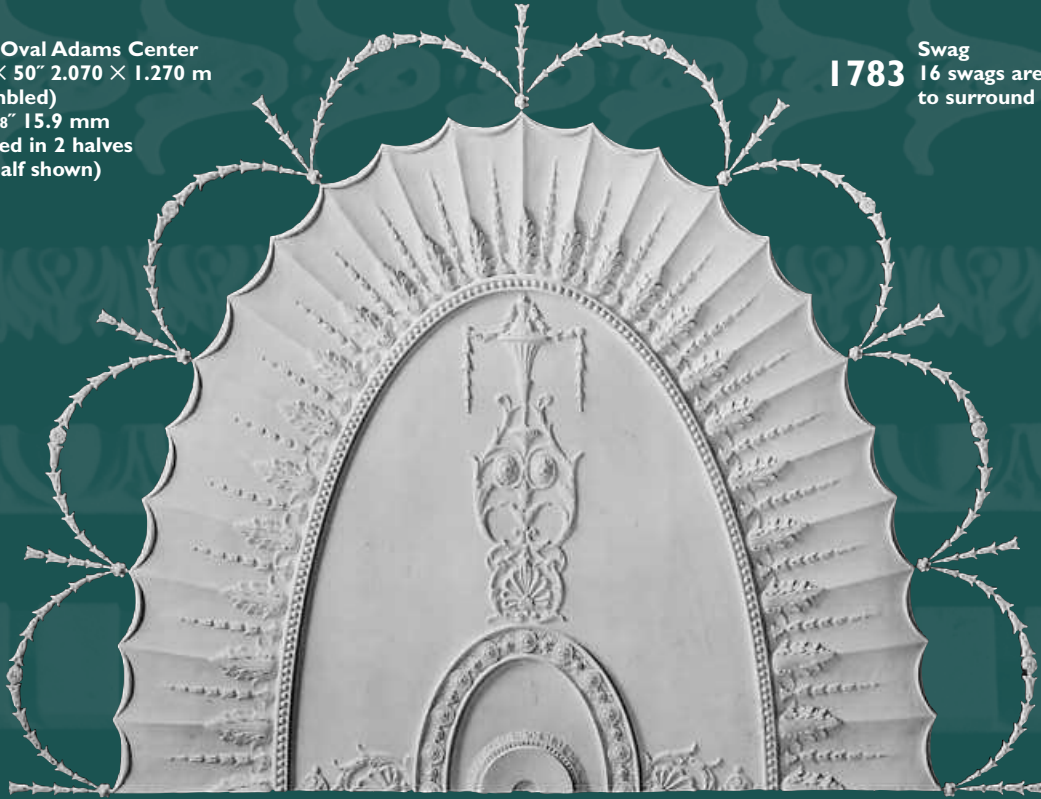

1783

Swag
16 swags are required
to surround the 1781

1755

Large Oval Adams Center
88" × 54" 2.235 × 1.372 m
(assembled)
Proj 1 1/8" 28.6 mm
Supplied in 2 halves
(one half shown)

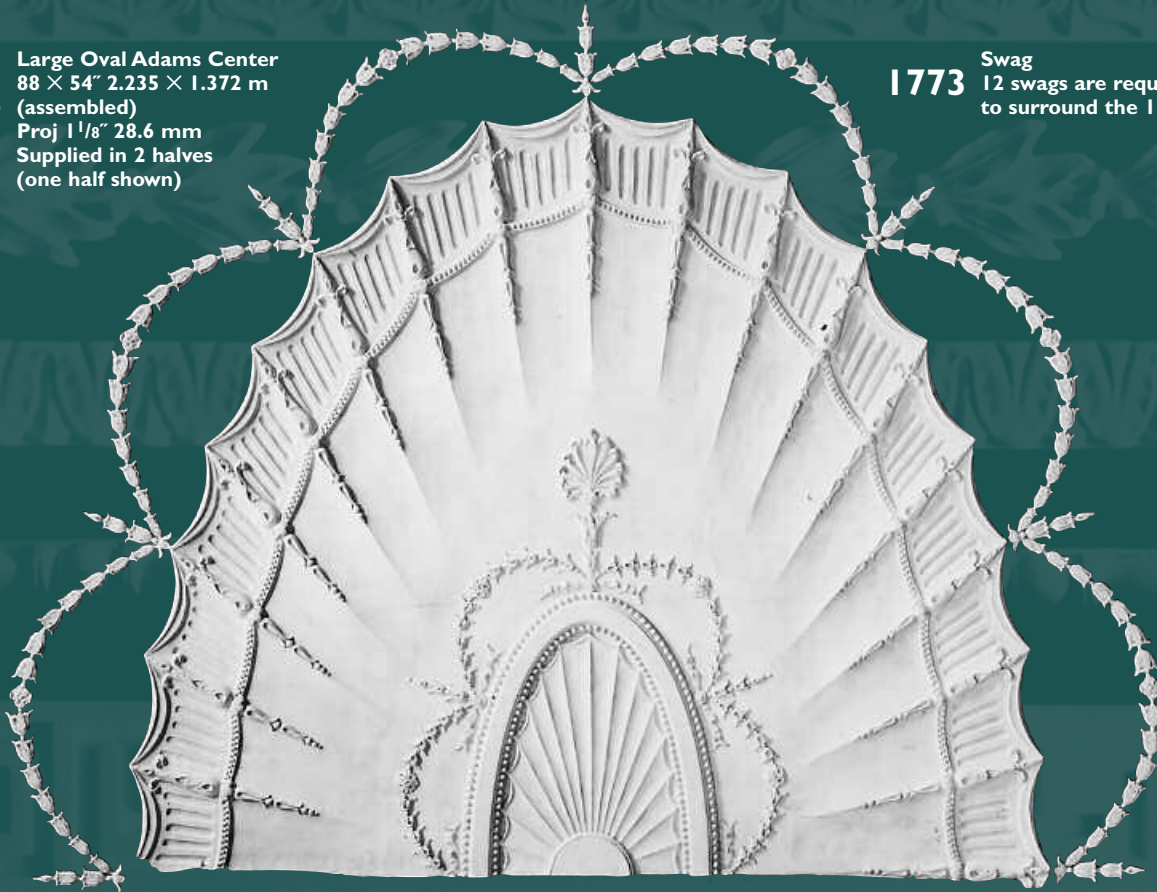

1773

Swag
12 swags are required
to surround the 1755

Gypsum Plaster Swags

459 Width 21 1/2" 546 mm
Height 7" 178 mm
Proj 1/2" 13 mm

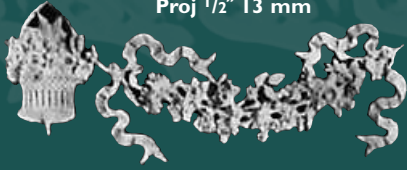

310 Width 19" 483 mm
Height 10 1/2" 267 mm
Proj 1" 25 mm

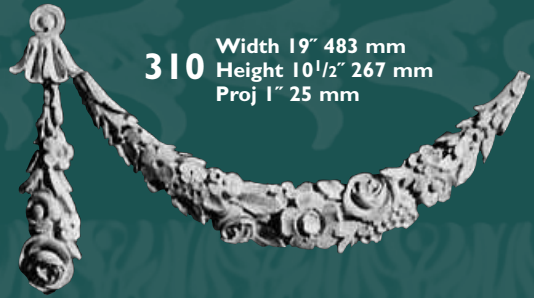

3057 Width 18" 457 mm
Height 6" 152 mm
Proj 1/4" 6.4 mm



460 Width 22" 559 mm
Height 8" 203 mm
Proj 1" 25 mm

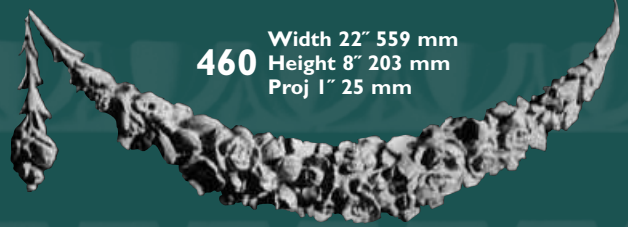

413 Width 14" 356 mm
Height 4 1/2" 114 mm
Proj 1/2" 13 mm



3336 Width 10" 254 mm
Depth 5 1/4" 133 mm
Proj 3/8" 9.5 mm



323 Width 10" 254 mm
Depth 6" 152 mm
Proj 3/8" 9.5 mm



1773 Width 19 1/2" 495 mm
Depth 7" 178 mm
Proj 1/4" 6.4 mm



1783 Width 13 1/4" 337 mm
Depth 6 1/2" 165 mm
Proj 5/8" 16 mm



1773A Width 19 1/2" 495 mm
Height 7" 178 mm
Proj 1/4" 6.4 mm

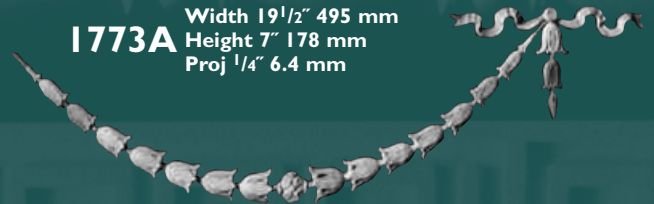

3354 Width 15" 381 mm
Depth 8" 203 mm
Proj 7/16" 11 mm



Gypsum Plaster Rosettes



17



29



28



35



1617



34



41



1642



1632



1730



1645



1728



1973



1715



1731



3801



3802



3803

Rosettes						
Number	Width		Length		Projection	
	inch	mm	inch	mm	inch	mm
9	4 1/4	108			3/8	10
17	4	102			3/8	10
28	3 5/8	92			3/8	10
29	3 5/8	92			3/8	10
34	3 1/2	89			1/4	6
35	3 1/2	89			1/4	6
41	3 1/4	83			3/8	10
1617	6 1/8	156			3/8	10
1632	5 3/4	146	8 1/4	210	3/8	10
1642	5 1/2	140			3/8	10
1645	4 1/4	108	7 1/4	184	1/2	13
1715	3 1/2	89			1/4	6
1728	4 5/8	118			1/2	13
1730	5 1/8	130			3/8	10
1731	4 7/8	124			1/2	13
1973	3 3/4	95			7/8	22
3801	4 3/8	111			1 5/8	41
3802	5	127			1 5/8	41
3803	6 1/4	156			1 5/8	41

Gypsum Cement Ceiling Domes

We stock a variety of plain and fluted gypsum domes with a variety of rim designs. We also supply custom plain spun domes with diameters of up to 12 feet. Each gypsum dome requires a ceiling recess for installation. Large domes are suspended from an integral exposed steel hanger like the one shown at the right. Smaller domes are suspended only by their rim with gypsum adhesive and (at least six) screws into joists or blocking through pre-drilled holes.



3465 / 3601 Gypsum Cement Ceiling Dome

Gypsum Cement Ceiling Domes

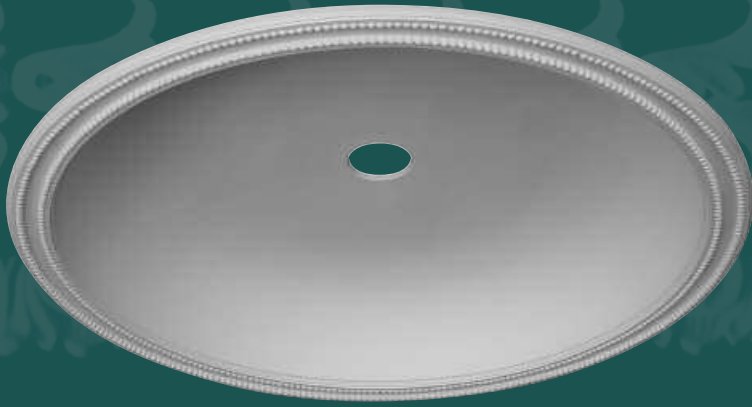

3465 Inner Diam 36" 914 mm
Outer Diam 42" 1067 mm
Depth 6 1/2" 165 mm

3601 Inner Diam 42 1/2" 1080 mm
Outer Diam 48" 1219 mm
Depth 8" 203 mm



3463 Inner Diam 36" 914 mm
Outer Diam 42 1/2" 1080 mm
Depth 13 1/2" 343 mm



3466 Inner Diam 25 1/2" 648 mm
Outer Diam 35" 889 mm
Depth 6 1/2" 165 mm



3462 Inner Diam 36" 914 mm
Outer Diam 42" 1067 mm
Depth 13 1/2" 343 mm



3461 Inner Diam 25 1/2" 648 mm
Outer Diam 32" 813 mm
Depth 6 1/2" 165 mm

Please note that the depth specified for each dome is the required framing depth of the dome (ie. the distance from the ceiling surface to the top back surface of the dome.) The diameter of the rough opening required for the dome is approximately the average of the inner and outer diameters.

Gypsum Cement Ceiling Domes



3464(A) Inside 52 × 62" 1.32 × 1.57 m
 Outside 59 1/2 × 69 1/2" 1.51 × 1.77 m
 Oval Dome Depth 18 1/2" 470 mm

Available with or without a laurel leaf rim inset:
 3464 has a plain rim, 3464A includes laurel inset



An 8 ft custom spun dome complete with light trough and fruit and flower band. Note the use of panel moulding to compliment the dome.

Custom Gypsum Domes

Custom plain round domes can be spun to any diameter up to 12 feet (3.66 m). Large custom domes are shipped in segments.

We offer a choice of rim designs for custom domes. The first option is a spun rim using the 3610 profile shown at the right. Another option is to add a laurel leaf inset (specify as rim 3610A). This results in a rim identical to a radial casting of the 3751 panel moulding with four inset rosettes. Both these options are shown above on the 3464(A) oval dome. The laurel inset is shown more clearly on the 3466 dome (on the previous page).

Another option is to use no rim — the dome simply mounts flush with the ceiling.

We also offer two standard spun light trough rim profiles: the 3611 for deep domes and the 3612 for shallow domes. The 3612A incorporates a laurel inset. The light trough profile itself can also be customized to meet your requirements.

Further options include the addition of a (separate) radial casting such as the fruit and flower band shown on the custom dome above at right. We have even supplied custom *fractured domes* which had a ragged segment of the dome removed.

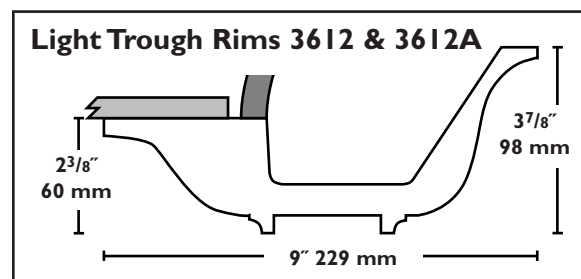
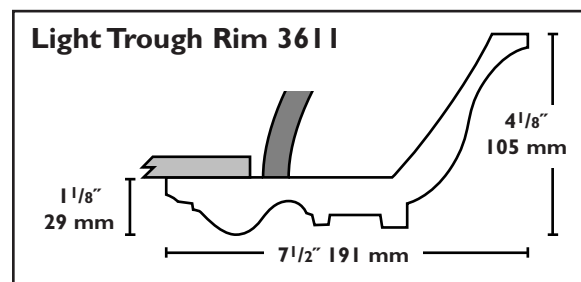
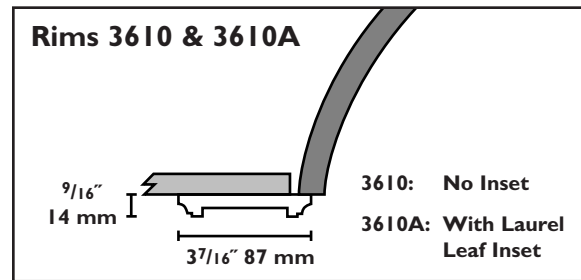

On This Page:

The 2058 ceiling. Pot lights have been incorporated in place of every other rosette.

Gypsum Ceiling Ornament & Tiles



Installing Gypsum Ceiling Ornament & Tiles

Installing Ceiling Ornament

It is important to plan a ceiling layout first on paper. For ceiling ornament, it is customary to leave from 6 to 12 inches as a border between the cornice and the perimeter ornament. Before fastening any ornament in place, lay out the ceiling with chalk lines, finding centers and laying out grids and outlines as appropriate.

A gypsum adhesive, such as Sheetrock 90, made by United States Gypsum Company, is recommended for the installation of ceiling ornament. Galvanized finishing nails are used to hold pieces in place while the adhesive sets. Nails are set on alternating 5 degree angles into the ceiling. They can either be placed through pre-drilled holes or simply on either side of (small) pieces and later removed.

Small pieces of ornament can be affixed using white glue.

Nail holes and joints are filled and blended using a sandable, paintable, non-shrinking filler.

Installing Ceiling Tiles

Before fastening any ceiling tiles in place, lay out the ceiling with chalk lines, finding centers and laying out grids and outlines as appropriate.

A gypsum adhesive, such as Sheetrock 90, made by United States Gypsum Company, is used to suspend ceiling tiles. Drywall screws through pre-drilled, counter-sunk holes, provide extra support and hold the tiles in place while the adhesive sets.

Screw holes and joints are filled and blended using a sandable, paintable, non-shrinking filler.

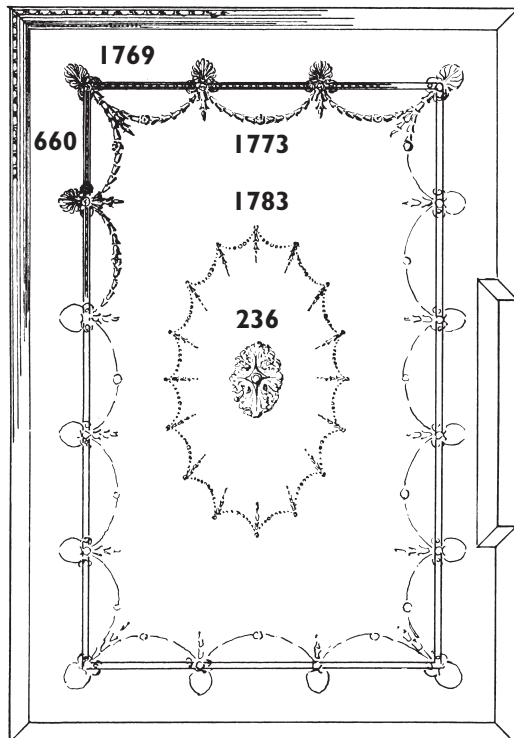
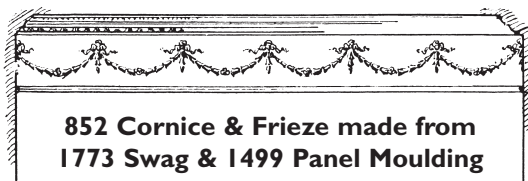

Suggestion for Adams Ceiling & Frieze

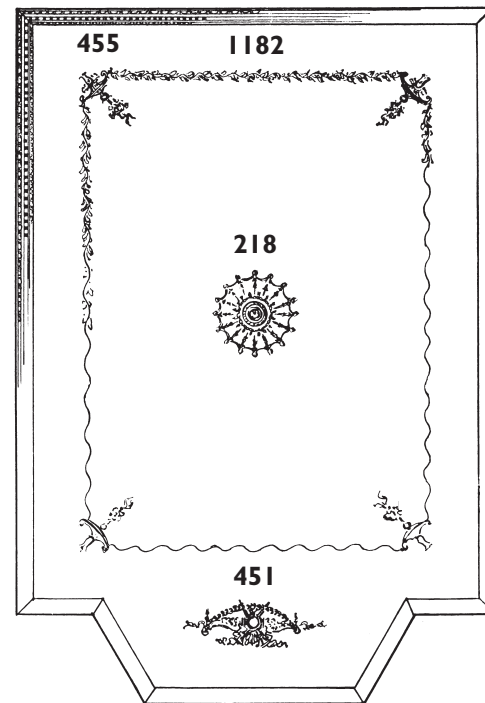

Suggestion for Georgian Ceiling & Frieze

Gypsum Plaster Spandrels & Ceiling Ornament

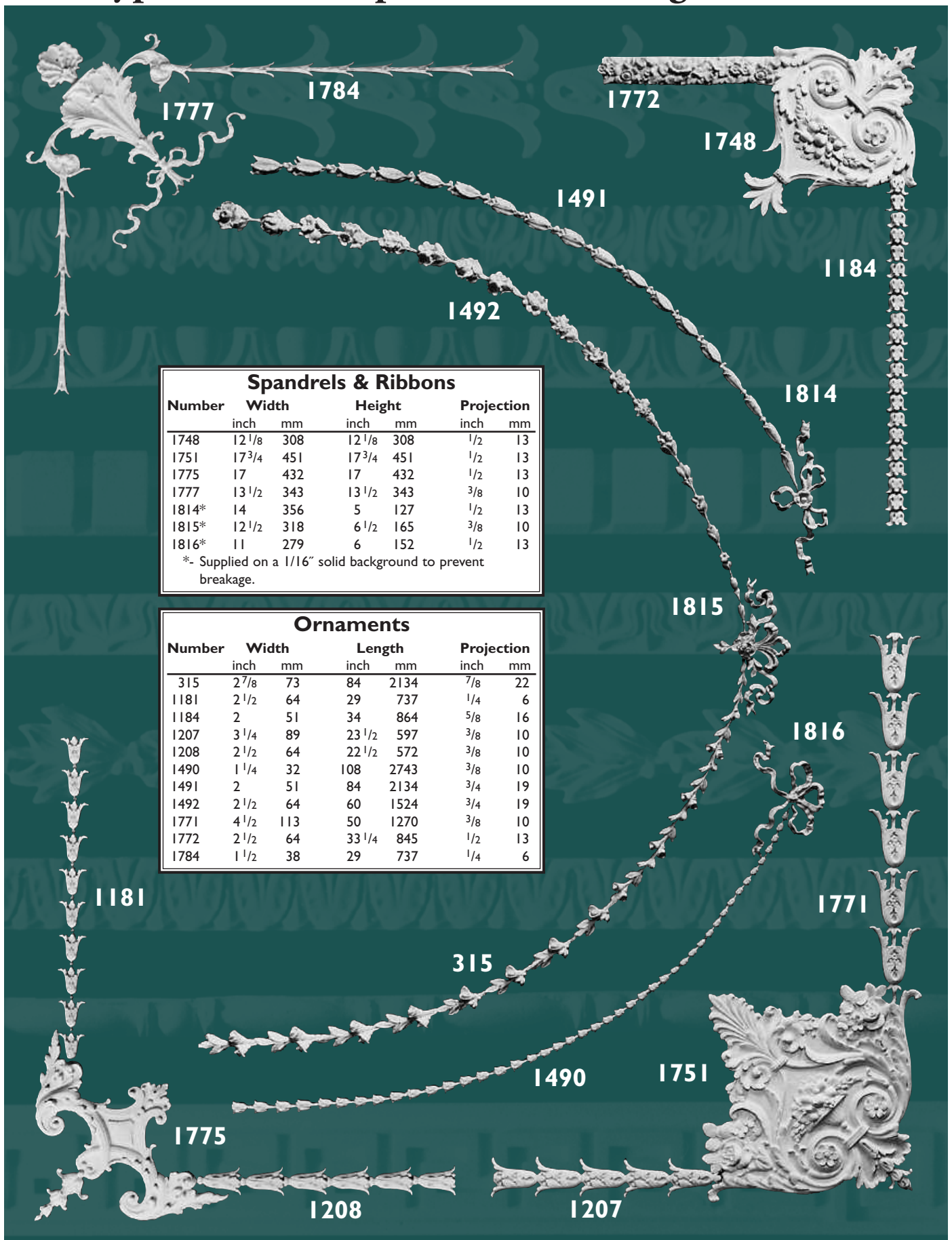

Spandrels & Ribbons

Number	Width		Height		Projection	
	inch	mm	inch	mm	inch	mm
1748	12 1/8	308	12 1/8	308	1/2	13
1751	17 3/4	451	17 3/4	451	1/2	13
1775	17	432	17	432	1/2	13
1777	13 1/2	343	13 1/2	343	3/8	10
1814*	14	356	5	127	1/2	13
1815*	12 1/2	318	6 1/2	165	3/8	10
1816*	11	279	6	152	1/2	13

*- Supplied on a 1/16" solid background to prevent breakage.

Ornaments

Number	Width		Length		Projection	
	inch	mm	inch	mm	inch	mm
315	2 7/8	73	84	2134	7/8	22
1181	2 1/2	64	29	737	1/4	6
1184	2	51	34	864	5/8	16
1207	3 1/4	89	23 1/2	597	3/8	10
1208	2 1/2	64	22 1/2	572	3/8	10
1490	1 1/4	32	108	2743	3/8	10
1491	2	51	84	2134	3/4	19
1492	2 1/2	64	60	1524	3/4	19
1771	4 1/2	113	50	1270	3/8	10
1772	2 1/2	64	33 1/4	845	1/2	13
1784	1 1/2	38	29	737	1/4	6

Gypsum Plaster Spandrels & Ceiling Ornament

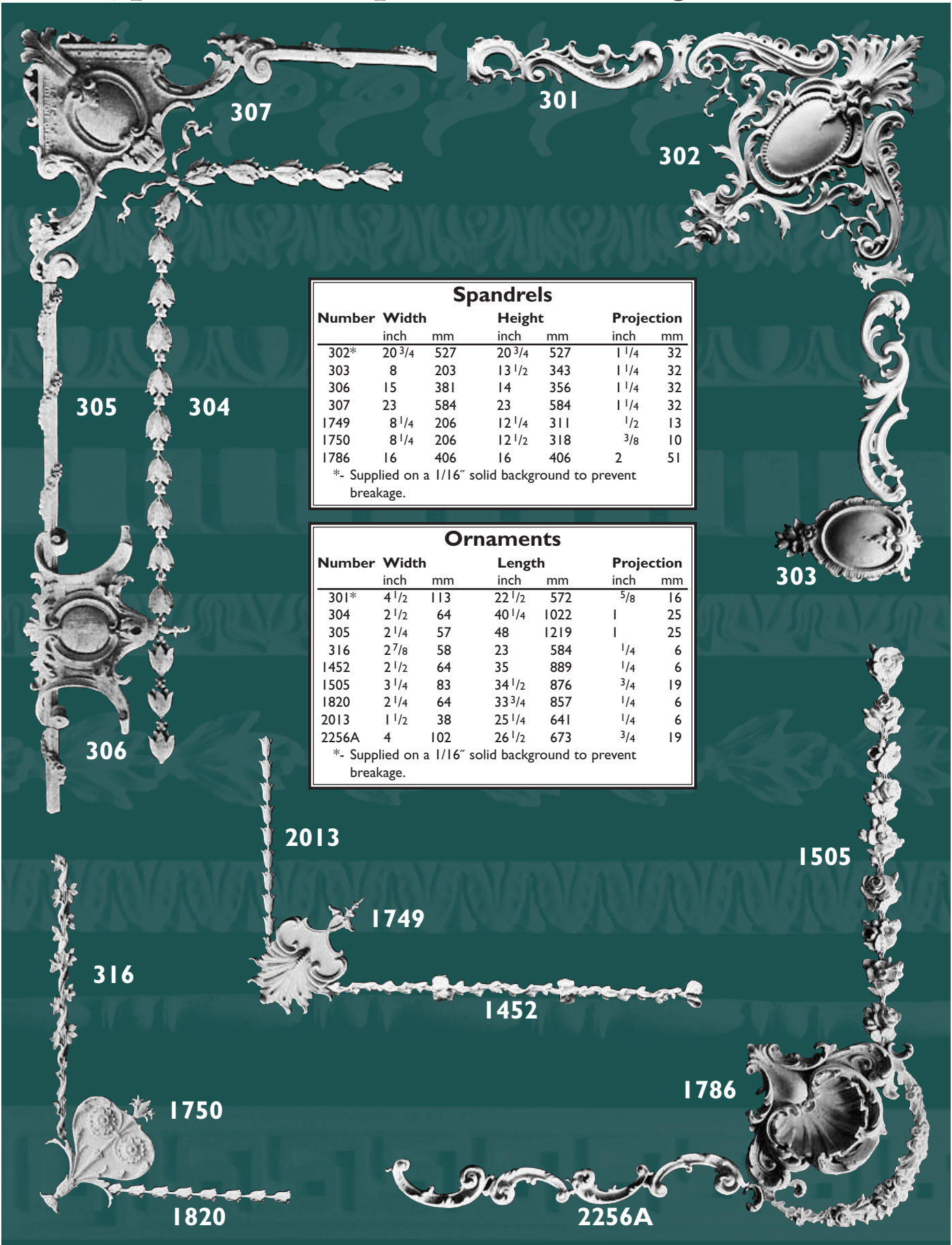

Spandrels						
Number	Width		Height		Projection	
	inch	mm	inch	mm	inch	mm
302*	20 3/4	527	20 3/4	527	1 1/4	32
303	8	203	13 1/2	343	1 1/4	32
306	15	381	14	356	1 1/4	32
307	23	584	23	584	1 1/4	32
1749	8 1/4	206	12 1/4	311	1/2	13
1750	8 1/4	206	12 1/2	318	3/8	10
1786	16	406	16	406	2	51

*- Supplied on a 1/16" solid background to prevent breakage.

Ornaments						
Number	Width		Length		Projection	
	inch	mm	inch	mm	inch	mm
301*	4 1/2	113	22 1/2	572	5/8	16
304	2 1/2	64	40 1/4	1022	1	25
305	2 1/4	57	48	1219	1	25
316	2 7/8	58	23	584	1/4	6
1452	2 1/2	64	35	889	1/4	6
1505	3 1/4	83	34 1/2	876	3/4	19
1820	2 1/4	64	33 3/4	857	1/4	6
2013	1 1/2	38	25 1/4	641	1/4	6
2256A	4	102	26 1/2	673	3/4	19

*- Supplied on a 1/16" solid background to prevent breakage.

Gypsum Plaster Spandrels & Ceiling Ornament

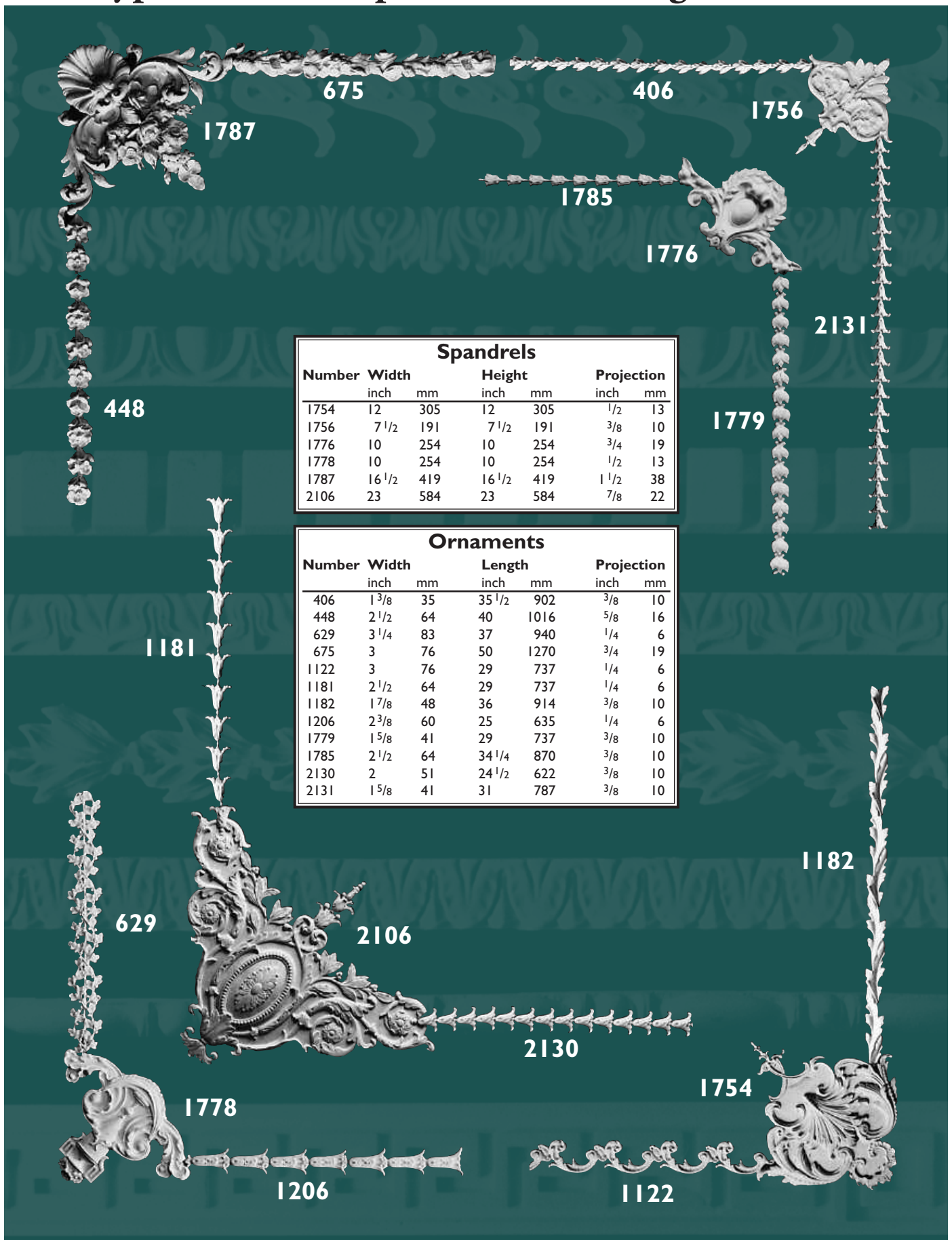

Spandrels						
Number	Width		Height		Projection	
	inch	mm	inch	mm	inch	mm
1754	12	305	12	305	1/2	13
1756	7 1/2	191	7 1/2	191	3/8	10
1776	10	254	10	254	3/4	19
1778	10	254	10	254	1/2	13
1787	16 1/2	419	16 1/2	419	1 1/2	38
2106	23	584	23	584	7/8	22

Ornaments						
Number	Width		Length		Projection	
	inch	mm	inch	mm	inch	mm
406	1 3/8	35	35 1/2	902	3/8	10
448	2 1/2	64	40	1016	5/8	16
629	3 1/4	83	37	940	1/4	6
675	3	76	50	1270	3/4	19
1122	3	76	29	737	1/4	6
1181	2 1/2	64	29	737	1/4	6
1182	1 7/8	48	36	914	3/8	10
1206	2 3/8	60	25	635	1/4	6
1779	1 5/8	41	29	737	3/8	10
1785	2 1/2	64	34 1/4	870	3/8	10
2130	2	51	24 1/2	622	3/8	10
2131	1 5/8	41	31	787	3/8	10

Gypsum Plaster Ceiling Tiles

1821B



The 1821B ceiling consists of two units which are laid out on a 46 1/2" grid. The existing ceiling becomes a background. Four units (two of each type) cover 15 sq. ft (1.39 sq. m). 36 units cover 135 sq. ft (12.6 sq. m).

2050



The 2050 ceiling consists of six component parts: the H-shaped 2050B plus five ornamented infils. Components are laid out on a 41 1/4 inch (1.05 m) grid. To cover 100 sq. ft (9.29 sq. m), 36 pieces are required plus cutting allowance.

2076



The 2076 and 2077 coffers are designed for use in standard suspended ceilings. The 2076 coffer has a depth of 3 inches (76 mm). The 2077 coffer is essentially flat with a maximum depth of 1 inch (25 mm). Both units measure 23 3/4 inch (603 mm) square.

2077



2050B



2050C



The 2050C ceiling consists of three component parts: the H-shaped 2050B plus two plain modulated infils. Components are laid out the same way as for the 2050. The 2050B can also be used alone without infils. 18 2050B units are required per 100 sq. ft (9.29 sq. m).

Gypsum Plaster Ceiling Tiles

2078



The 2078 ceiling is supplied in three-coffer sections which measure $53\frac{7}{8}$ by $17\frac{7}{8}$ inches (1368 by 454 mm) with a projection of $2\frac{3}{8}$ inches (60 mm).

2074



Max. projection: $1\frac{1}{4}$ " (32 mm)

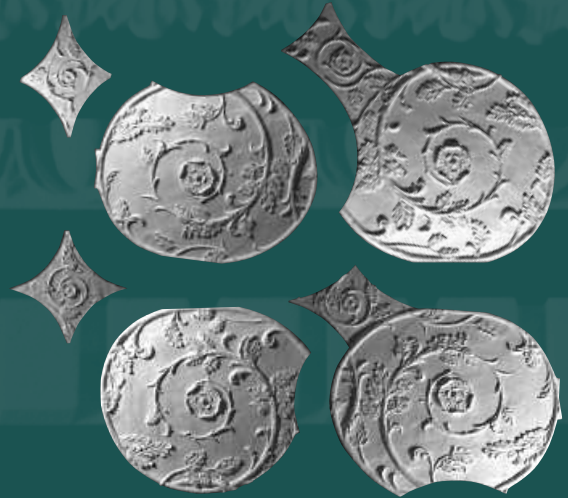

The 2074 ceiling consists of six units which fit together as shown above. Assembled, the six pieces cover an area 70×81 inches (1.78×2.06 m). 24 pieces (4 of each type) cover 157.5 sq. ft (14.63 sq. m) as an area $11' 8" \times 13' 6"$ (3.56×4.11 m).

2057

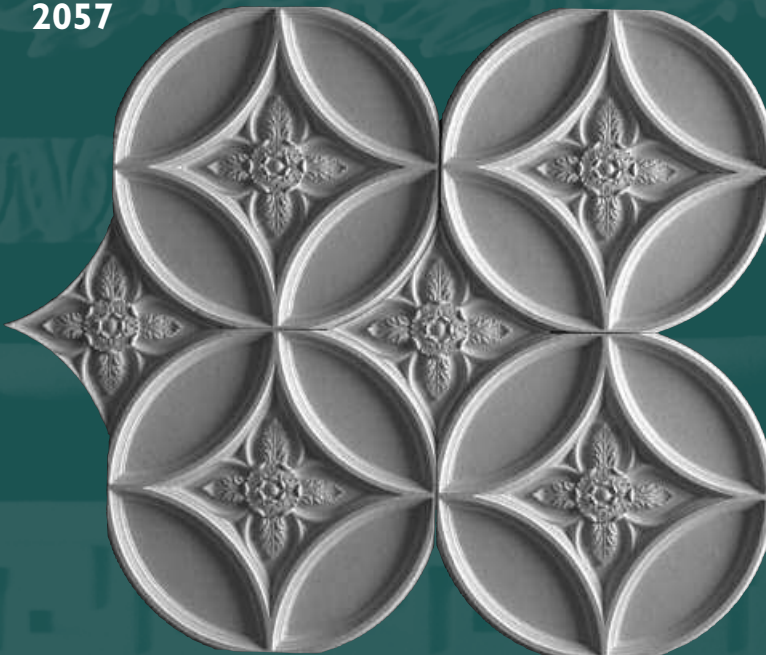

Max. projection: $1\frac{1}{4}$ " (32 mm)

The 2057 ceiling consists of two components. The round piece is approximately 2 feet in diameter. 25 round pieces plus 25 rosette infills will cover 100 sq. ft (9.29 sq. m).

Gypsum Plaster Ceiling Tiles



Max. projection: 1 1/4" (32 mm)

2058

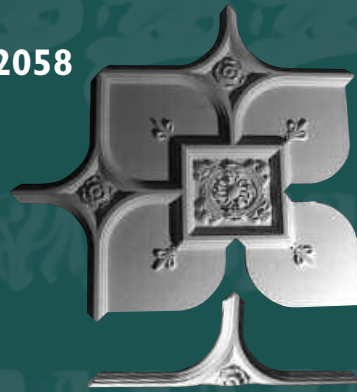

2058A

The 2058 ceiling consists of one primary component and the 2058A border piece. The principal piece measures 32 × 34 inches (813 × 864 mm). 16 pieces cover 114 sq. ft (10.6 sq. m).

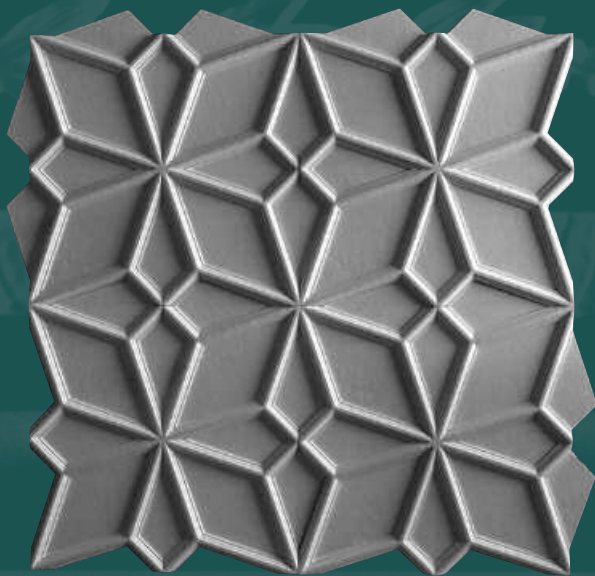

Max. projection: 1 1/8" (29 mm)

2059

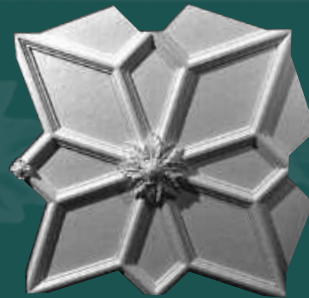

2059C



2059B



2059A

The 2059 ceiling consists of one primary component, the 2059C border piece, and two optional rosettes: the 2059A and 2059B. The principal piece measures 31 1/4 inches (794 mm) square. 16 pieces cover 108 sq. ft (10.1 sq. m).

Gypsum Columns, Pilasters & Capitals

The orders of classical architecture were established during the 16th century by Italian Renaissance scholars. By studying the remains of buildings built during the Roman empire before the 5th century and the ancient writings of Vitruvius, a proportional system for the design of columns and horizontal supports was defined which became a basis for architectural design. The five classical orders each defined a set of proportions for the design of entablatures, columns and pedestals. They were named the Tuscan, Doric, Ionic, Corinthian, and Composite Orders.

The principal difference between the orders is in the proportion of the columns. Tuscan columns are the thickest, Corinthian and Composite columns are thinner. The style and height of a column's capital also varies from order to order. Tuscan and Doric capitals are plain, spun shapes. Composite capitals are highly ornate.

Columns may be fluted or plain. All classical columns include *entasis*, an even narrowing from a distance 1/3 of

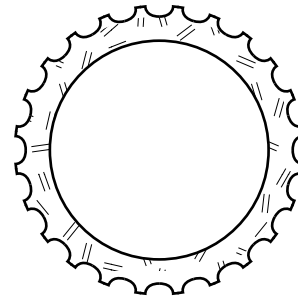

Section of a Fluted Column Shaft

the way up the column shaft to its neck. Entasis greatly enhances the appearance of the large columns the orders describe. Smaller columns often look better without entasis.

Today, columns have found many decorative uses in the interior of a residence, office, or institutional building. They are very effective as room dividers in lieu of partitions to create a visual division between areas of rooms, in entries, under arches or beams, singly or in pairs.

Pilasters are the *flat to the wall* counterpart of columns. Classically, pilasters were mated with columns. Today, they are often used in pairs margining doors, framing full height mirrors, dividing wall areas or bordering an area such as a buffet. Used with a pediment, pilasters make a very elegant door trim. Pilasters are typically straight but may include entasis if they are to be mated with an entasis column. In addition to our classical pilasters, we offer three ornamental pilasters (shown at the right).

Balmer supplies complete columns and pilasters made from our wide selection of separate capitals, shafts, and bases. Alternatively, you can order only capitals or bases and supply your own shaft.

All of our columns and pilasters are produced in a very hard and dense gypsum cement, three times as hard as plaster. Our 8 inch diameter, 5/8 inch thick fluted column rings like a steel pipe when tapped. These products are designed as decorative non-structural components. Columns are, however, hollow and can be supplied in halves for installation around load bearing posts.

A wood plinth is recommended under columns and pilasters used without a pedestal to prevent abuse from cleaning utensils. The plinth beneath a pilaster should be roughly the same height as the baseboard.

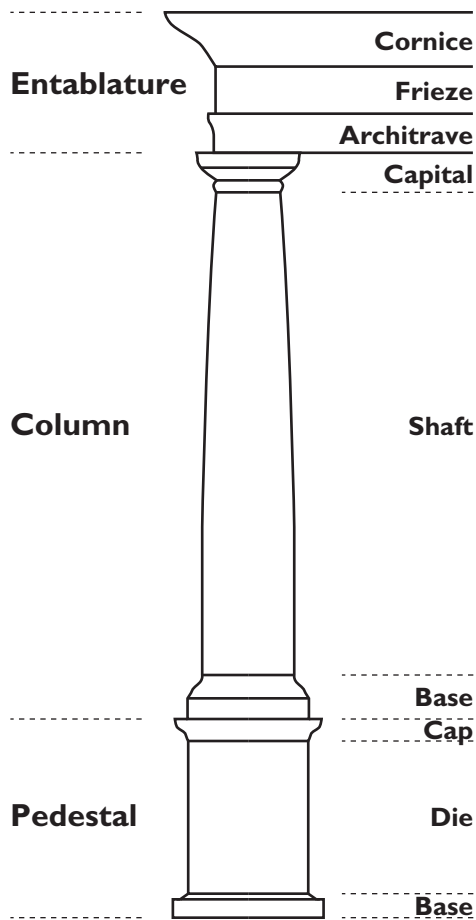

The Parts of an Order of Classical Architecture

Gypsum Ornamental Pilasters



Ornamental Pilasters						
Number	Width		Height		Projection	
	inch	mm	inch	mm	inch	mm
1908	10	254	76	1930	1	25
3391	8	203	70 1/2	1791	1 3/8	35
3392	8	203	100 5/8	2556	2	51

Gypsum Plaster Pediments

1910



8924



2923

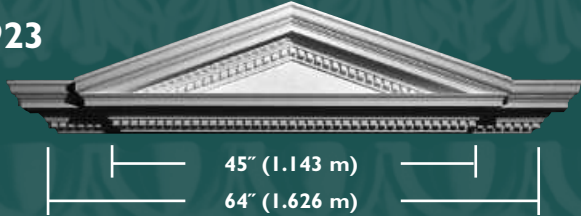

8925

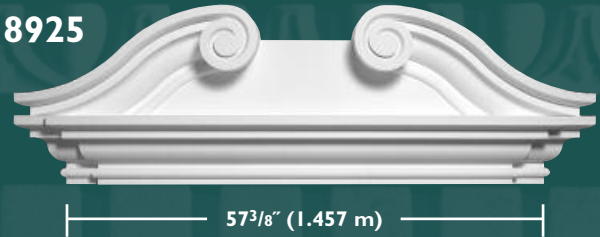

2924

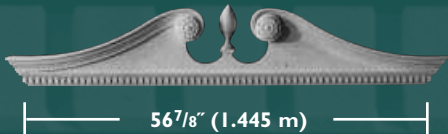

8926



2926

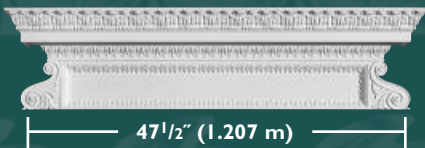

8927



3417



8930



Pediments							Pediments						
Number	Width		Height		Projection		Number	Width		Height		Projection	
	inch	mm	inch	mm	inch	mm		inch	mm	inch	mm	inch	mm
1910	61 3/4	1568	18 1/2	470	5	127	8924	66 1/4	1683	25 1/4	641	6 1/4	159
2923	72 3/4	1848	16	406	7 5/8	194	8925	67 1/4	1708	20 1/2	521	9 1/4	235
2924	60 7/8	1546	11 1/2	292	5	127	8926	64 3/4	1645	8 3/4	222	5	127
2926	50 1/4	1276	11 5/8	295	6	152	8927	50 1/4	1276	12 3/4	324	6 1/4	159
3417	95 1/4	2419	20 1/4	514	5	127	8930	56	1422	10 3/4	273	3 1/4	83

Gypsum Plaster Capitals

Doric Column Capitals



Number	Column Dia.		Max. Dia.		Height	
	inch	mm	inch	mm	inch	mm
762a	4	102	6 ⁵ / ₈	168	3 ³ / ₈	85
762b	5	127	8 ¹ / ₄	210	4 ³ / ₁₆	106
762c	6	152	10	254	5	127
762d	7	178	11 ⁵ / ₈	295	5 ⁷ / ₈	149
762e	8	203	13 ³ / ₈	340	6 ¹¹ / ₁₆	170
762f	9	229	15	381	7 ¹ / ₂	191
762g	10	254	16 ⁵ / ₈	422	8 ³ / ₈	212
762h	11	279	18 ¹ / ₄	464	9 ³ / ₁₆	234
762i	12	305	19 ⁷ / ₈	505	10	255

Doric Pilaster Capitals



Number	Pilaster Width		Pilaster Depth		Max. Width		Height	
	inch	mm	inch	mm	inch	mm	inch	mm
763a	4	102	2	51	6 ⁵ / ₈	168	3 ³ / ₈	85
763b	5	127	2 ¹ / ₂	64	8 ¹ / ₄	210	4 ³ / ₁₆	106
763c	6	152	3	76	10	254	5	127
763d	7	178	3 ¹ / ₂	89	11 ⁵ / ₈	295	5 ⁷ / ₈	149
763e	8	203	4	102	13 ³ / ₈	340	6 ¹¹ / ₁₆	170
763f	9	229	4 ¹ / ₂	114	15	381	7 ¹ / ₂	191
763g	10	254	5	127	16 ⁵ / ₈	422	8 ³ / ₈	212
763h	11	279	5 ¹ / ₂	140	18 ¹ / ₄	464	9 ³ / ₁₆	234
763i	12	305	6	152	19 ⁷ / ₈	505	10	255

Tuscan Column Capitals



Number	Column Dia.		Width at Top		Height	
	inch	mm	inch	mm	inch	mm
764e	8	203	13 ¹¹ / ₁₆	348	7 ⁵ / ₁₆	186
764g	10	254	16 ⁹ / ₁₆	421	8 ⁷ / ₁₆	214
764i	12	305	19 ¹ / ₂	495	9 ⁵ / ₈	244

Scamozzi Ionic Column Capitals



Number	Column Dia.		Max. Width		Height	
	inch	mm	inch	mm	inch	mm
782a	4 ¹ / ₂	102	7 ⁷ / ₈	200	2 ³ / ₈	60
782b	5	127	8 ¹ / ₄	210	3	76
782c	7	178	11 ³ / ₄	298	3 ⁵ / ₈	92
782d	9	229	15 ³ / ₄	400	4 ⁷ / ₈	124
782e	11	279	19 ¹ / ₄	489	5 ⁵ / ₈	143
782f	12	305	19 ³ / ₄	502	4 ³ / ₄	121
701	14	356	21 ³ / ₄	552	4 ³ / ₄	121

Scamozzi Ionic Pilaster Capitals



Number	Pilaster Width		Pilaster Depth		Max. Width		Height	
	inch	mm	inch	mm	inch	mm	inch	mm
782g	8 ¹ / ₂	216	4 ¹ / ₄	108	15 ¹ / ₂	394	4 ⁷ / ₈	124
782h	11	279	5 ¹ / ₂	140	18 ¹ / ₂	470	5 ¹ / ₂	140
782i	12	305	6	152	19 ⁵ / ₈	498	5	127
703	13 ¹ / ₂	343	6 ³ / ₄	171	25 ⁵ / ₈	651	8 ¹ / ₄	210

Gypsum Plaster Capitals

Classic Ionic Column Capitals



Number	Column Dia.		Max. Width		Height	
	inch	mm	inch	mm	inch	mm
735a	6	152	10 1/4	260	3	76
735b	7	178	12 1/4	311	3 7/8	98
735c	8	203	13 1/4	337	4 1/8	105
735d	9	229	15 1/4	387	4 3/4	121
735e	10	254	16 1/8	410	4 5/8	117

Classic Ionic Pilaster Capitals



Number	Pilaster Width		Pilaster Depth		Max. Width		Height	
	inch	mm	inch	mm	inch	mm	inch	mm
735f	6	152	3	76	10 1/16	256	3	76
735g	7	178	3 1/2	89	12 3/4	324	3 7/8	98
735h	8	203	4	102	13 1/2	343	4 1/4	108
735i	9	229	4 1/2	114	16 3/4	425	4 3/4	121
735j	10	254	5	127	17 1/2	445	4 3/4	121

Corinthian Column Capitals



Number	Column Dia.		Max. Width		Height	
	inch	mm	inch	mm	inch	mm
2983	4	102	6 3/4	171	5 1/2	140
719	8	203	13 7/8	352	12 1/4	311
3547	10	254	16 3/4	425	15	381
3200	12	305	20 1/2	521	17 1/4	438
3422	16	406	29 1/4	743	24 1/2	622
726	17	432	29 3/4	756	27 1/2	699
3202	22 1/2	572	33 1/4	845	29	737

Corinthian Pilaster Capitals



Number	Pilaster Width		Pilaster Depth		Max. Width		Height	
	inch	mm	inch	mm	inch	mm	inch	mm
2978	3	76	1 3/8	35	5	127	4 5/8	117
3228	3	76	1 1/2	38	5	127	5	127
2982	4	102	2 1/8	54	7	178	5 1/2	140
714	8	203	4	102	14 7/8	378	11 7/8	302
3547a	10	254	5	127	17 5/8	448	15 1/8	384
3201	12	305	6	152	20 1/2	521	18 1/4	464
3422a	16	406	8	203	30	762	27	686
760	17 1/2	445	2 1/2	64	31	787	27 1/4	692

Gypsum Plaster Capitals

Greek Corinthian Column Capitals

Number	Column Dia.		Max. Width		Height	
	inch	mm	inch	mm	inch	mm
3210	8	203	15 1/8	384	16 1/2	419
3425	9 3/4	248	16 1/2	419	11 5/8	295
7905	10	254	15 1/4	387	12	305
3383	11	279	17 3/8	441	16 1/4	413



3210



7905



3383



3425

Greek Corinthian Pilaster Capitals



3398



3209



3382



3385

Number	Pilaster Width		Pilaster Depth		Max. Width		Height	
	inch	mm	inch	mm	inch	mm	inch	mm
3398	6	152	1 1/2	38	9 1/2	241	9	229
3209	8	203	3	76	15 1/16	383	16	406
3382	10 3/4	273	3 1/8	79	17 1/2	445	17 1/4	438
3385	30 1/2	775	2 1/2	64	37	940	16 1/4	413

Renaissance Composite Column Capitals

Number	Column Dia.		Max. Width		Height	
	inch	mm	inch	mm	inch	mm
2991	2	51	4 3/4	121	5	127
1883	5 1/4	133	9 1/4	235	7 1/4	184
3390	5 7/8	149	10 3/4	273	8	203
1884	6	152	9 1/4	235	8 1/4	210
1899	6	152	10 1/2	267	7 3/4	197
2401	6	152	8 3/4	222	9	229
2992	7	178	8 3/8	213	9 1/2	241
3426	7	178	11 1/2	292	2 3/4	70
3424	8	203	13 1/8	333	6 1/2	165
713	9	229	17	432	15 1/4	387
3428	10 1/4	260	16 1/8	410	5	127



2991



1883



3424



3390



3426



1899



1884



2401



2992



713



3428

Gypsum Plaster Capitals

Renaissance Composite Pilaster Capitals



1898



1885

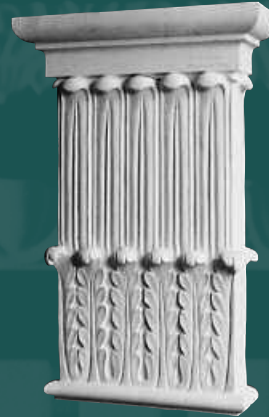

3384



2995



722



733



715



7902



3386



3423

Number	Pilaster Width		Pilaster Depth		Max. Width		Height	
	inch	mm	inch	mm	inch	mm	inch	mm
1898	6	152	3	76	10	254	7 ¹ / ₄	184
1885	6	152	3	76	9 ¹ / ₄	235	8 ³ / ₈	213
2995	8	203	1 ¹ / ₂	38	10 ¹ / ₄	260	10 ¹ / ₂	267
722a	8	203	1 ³ / ₄	44	11 ⁵ / ₈	295	12 ¹ / ₈	308
722b	9	229	1 ³ / ₄	44	12 ⁷ / ₈	327	12 ³ / ₄	324
722c	10	254	2	51	13 ³ / ₄	349	12 ³ / ₄	324
733	9	229	4 ¹ / ₂	114	17	432	15 ¹ / ₄	387
7902	10	254	2 ¹ / ₄	57	13 ³ / ₈	340	16	406
715	11	279	2	51	16 ¹ / ₂	419	17 ¹ / ₄	438
3386	11	279	1 ³ / ₄	45	14 ³ / ₈	365	15 ¹ / ₈	384
3384	11 ³ / ₄	298	2 ¹ / ₂	64	16 ¹ / ₈	410	24	610
3423	13	330	1 ¹ / ₂	38	23 ¹ / ₈	587	6 ¹ / ₂	165
720	15	381	2 ³ / ₄	70	18 ³ / ₄	476	16	406



720

Gypsum Plaster Column & Pilaster Bases



**3407 Single Bullnose
Column Base**



**3408 Double Bullnose
Column Base**

Bases are available in two styles and 12 sizes for both columns and pilasters. When ordering a column base, provide the column diameter (at the base). For a pilaster base, provide the pilaster width (at the base). Pilaster bases ordered alone (ie. without a Balmer pilaster shaft) are supplied to surround a pilaster projection of one-half the pilaster's width. They can easily be trimmed for pilasters with less projection.

Note that all of our bases mount around, not beneath, a column or pilaster. The base height therefore does not affect column or pilaster height. Columns and pilasters stand directly on the floor or plinth.



**3607 Single Bullnose
Pilaster Base**



**3608 Double Bullnose
Pilaster Base**

Single Bullnose Column Bases

Number	Column Dia.		Max. Dia.		Height	
	inch	mm	inch	mm	inch	mm
3407a	4	102	6 ³ / ₈	162	1 ⁷ / ₈	48
3407b	5	127	7 ³ / ₈	187	1 ⁷ / ₈	48
3407c	6	152	9 ¹ / ₄	235	2 ⁵ / ₈	67
3407d	7	178	10 ¹ / ₄	260	2 ⁵ / ₈	67
3407e	7 ¹ / ₂	191	10 ³ / ₄	273	2 ⁵ / ₈	67
3407f	8	203	11 ¹ / ₄	286	2 ⁵ / ₈	67
3407g	8 ¹ / ₂	216	11 ³ / ₄	298	2 ⁵ / ₈	67
3407h	9	229	12 ¹ / ₄	311	2 ⁵ / ₈	67
3407i	10	254	13 ¹ / ₄	337	2 ⁵ / ₈	67
3407j	11	279	15	381	3 ¹ / ₄	95
3407k	12	305	16	406	3 ¹ / ₄	95
3407l	14	356	18	457	3 ¹ / ₄	95

Single Bullnose Pilaster Bases

Number	Pilaster Width		Max. Width		Height	
	inch	mm	inch	mm	inch	mm
3607a	4	102	6 ³ / ₈	162	1 ⁷ / ₈	48
3607b	5	127	7 ³ / ₈	187	1 ⁷ / ₈	48
3607c	6	152	9 ¹ / ₄	235	2 ⁵ / ₈	67
3607d	7	178	10 ¹ / ₄	260	2 ⁵ / ₈	67
3607e	7 ¹ / ₂	191	10 ³ / ₄	273	2 ⁵ / ₈	67
3607f	8	203	11 ¹ / ₄	286	2 ⁵ / ₈	67
3607g	8 ¹ / ₂	216	11 ³ / ₄	298	2 ⁵ / ₈	67
3607h	9	229	12 ¹ / ₄	311	2 ⁵ / ₈	67
3607i	10	254	13 ¹ / ₄	337	2 ⁵ / ₈	67
3607j	11	279	15	381	3 ¹ / ₄	95
3607k	12	305	16	406	3 ¹ / ₄	95
3607l	14	356	18	457	3 ¹ / ₄	95

Double Bullnose Column Bases

Number	Column Dia.		Max. Dia.		Height	
	inch	mm	inch	mm	inch	mm
3408a	4	102	6 ¹ / ₄	159	3 ⁵ / ₈	143
3408b	5	127	7 ¹ / ₄	184	3 ⁵ / ₈	143
3408c	6	152	10 ¹ / ₂	254	7 ¹ / ₄	184
3408d	7	178	11 ¹ / ₂	279	7 ¹ / ₄	184
3408e	7 ¹ / ₂	191	12	305	7 ¹ / ₄	184
3408f	8	203	12 ¹ / ₂	318	7 ¹ / ₄	184
3408g	8 ¹ / ₂	216	13	330	7 ¹ / ₄	184
3408h	9	229	13 ¹ / ₂	343	7 ¹ / ₄	184
3408i	10	254	14 ¹ / ₂	368	7 ¹ / ₄	184
3408j	11	279	17 ¹ / ₂	445	10 ⁷ / ₈	276
3408k	12	305	18 ¹ / ₂	470	10 ⁷ / ₈	276
3408l	14	356	20 ⁵ / ₈	524	10 ⁷ / ₈	276

Double Bullnose Pilaster Bases

Number	Pilaster Width		Max. Width		Height	
	inch	mm	inch	mm	inch	mm
3608a	4	102	6 ¹ / ₄	159	3 ⁵ / ₈	143
3608b	5	127	7 ¹ / ₄	184	3 ⁵ / ₈	143
3608c	6	152	10 ¹ / ₂	254	7 ¹ / ₄	184
3608d	7	178	11 ¹ / ₂	279	7 ¹ / ₄	184
3608e	7 ¹ / ₂	191	12	305	7 ¹ / ₄	184
3608f	8	203	12 ¹ / ₂	318	7 ¹ / ₄	184
3608g	8 ¹ / ₂	216	13	330	7 ¹ / ₄	184
3608h	9	229	13 ¹ / ₂	343	7 ¹ / ₄	184
3608i	10	254	14 ¹ / ₂	368	7 ¹ / ₄	184
3608j	11	279	17 ¹ / ₂	445	10 ⁷ / ₈	276
3608k	12	305	18 ¹ / ₂	470	10 ⁷ / ₈	276
3608l	14	356	20 ⁵ / ₈	524	10 ⁷ / ₈	276

Gypsum Cement Column Shafts

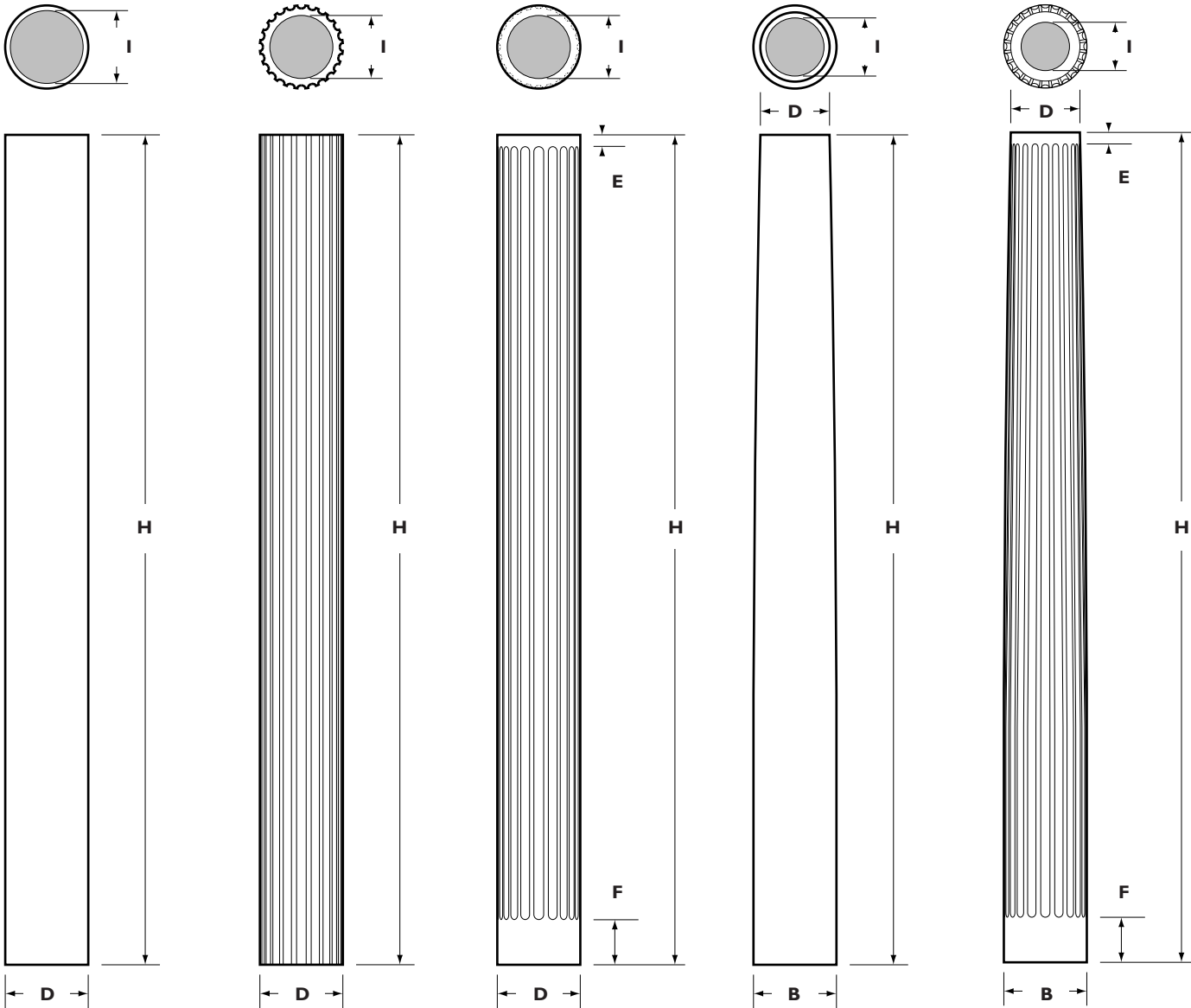

Style 1:
Plain, Straight
Shaft

Style 2:
Fluted, Straight
Shaft

Style 3:
Fluted, Straight
Shaft with
Endflutes

Style 4:
Plain, Entasis
Shaft

Style 5:
Fluted, Entasis
Shaft with
Endflutes

Gypsum Cement Column Shafts

Number	Style	H		D		B		I		E		F	
		inch	m	inch	mm	inch	mm	inch	mm	inch	mm	inch	mm
Standard Column Shafts													
5001A	1	83 1/8	2.111	4	102			3	76				
5001B	1	88 1/2	2.248	5	127			4	102				
5001C	1	94 1/2	2.400	6	152			5	127				
5001D	1	97 7/8	2.486	7	178			6	152				
5001E	1	105 3/8	2.677	8	203			6 3/4	171				
5001F	1	110 3/4	2.813	9	229			8	203				
5001G	1	116 7/8	2.969	10	254			8 1/2	216				
5001H	1	116	2.946	11	279			10	254				
5001I	1	116 1/4	2.953	12	305			11	279				
5002A	2	83 1/8	2.111	4	102			2 1/2	64				
5002B	2	88 1/2	2.248	5	127			3 1/2	89				
5002C	2	94 1/2	2.400	6	152			4 1/2	114				
5002D	2	97 7/8	2.486	7	178			5 1/2	140				
5002E	2	105 3/8	2.677	8	203			6 1/2	165				
5002F	2	110 3/4	2.813	9	229			7	178				
5002G	2	116 7/8	2.969	10	254			8	203				
5002H	2	116	2.946	11	279			9	229				
5002I	2	116 3/4	2.965	12	305			10	254				
5003A	3	83 1/8	2.111	4	102			2 1/2	63	3/4	19	6 1/8	156
5003B	3	88 1/2	2.248	5	127			3 1/2	89	3/4	19	9 1/8	232
5003C	3	94 1/2	2.400	6	152			4 1/2	114	3/4	19	10 1/4	260
5003D	3	97 7/8	2.486	7	178			5 1/2	140	3/4	19	10 1/4	260
5003E	3	105 3/8	2.677	8	203			6 1/2	165	3/4	19	10 3/4	273
5003F	3	110 3/4	2.813	9	229			7	178	3/4	19	10 3/4	273
5003G	3	116 7/8	2.969	10	254			8	203	3/4	19	11 3/4	299
5003H	3	116	2.946	11	279			9	229	3/4	19	15 3/8	391
5003I	3	116 3/4	2.965	12	305			10	254	3/4	19	15 3/8	391
5004C	4	94 1/2	2.400	6	152	7 1/2	191	4 1/2	114				
5004D	4	97 7/8	2.486	7	178	8 1/2	216	5 1/2	140				
5004E	4	105 3/8	2.677	8	203	10	254	6 1/2	165				
5004G	4	116 7/8	2.969	10	254	12	305	8	203				
5004I	4	116 3/4	2.965	12	305	14	356	10	254				
5005C	5	94 1/2	2.400	6	152	7 1/2	191	4 1/2	114	3/4	19	10 1/4	260
5005D	5	97 7/8	2.486	7	178	8 1/2	216	5 1/2	140	3/4	19	10 1/4	260
5005E	5	105 3/8	2.677	8	203	10	254	6 1/2	165	3/4	19	10 3/4	273
5005G	5	116 7/8	2.969	10	254	12	305	8	203	3/4	19	11 3/4	299
5005I	5	116 3/4	2.965	12	305	14	356	10	254	3/4	19	15 3/8	391
Non-standard Column Shafts													
5502	2	96	2.438	6	152			4 3/4	121				
5503	2	103 3/4	2.635	8	203			6 1/4	159				
5504	3	87 1/4	2.216	10	254			9	229	3/4	19	1/4 (3)	6
5506	4	90 1/4	2.292	4 1/2	114	5 1/2	140	3 1/2	89				
5509	4	91 3/4	2.330	7 1/4	184	8 1/2	216	6 1/4	159				
5510	4	108	2.743	11 3/8	289	13	330	10 3/8	264				
5511	4	109 3/4	2.788	15	381	18	457	14	356				
5512	5	82 1/2	2.096	7	178	8 1/4	210	6	152	0	0	1/2	13
5513	5	103 1/2	2.629	8 1/4	210	10 1/8	257	6 3/4	171	1/2	13	9	229
5514	5	74 1/2	1.892	8 1/2	216	9 3/4	248	6	152	1/2	13	3/4	19
5516	5	99 1/2	2.527	9	229	10 3/4	273	8	203	1/2	13	5 1/4	57
5517	5	95 7/8	2.435	12	305	14	356	9 3/4	248	3/4	19	4 3/4	121

Gypsum Cement Pilaster Shafts

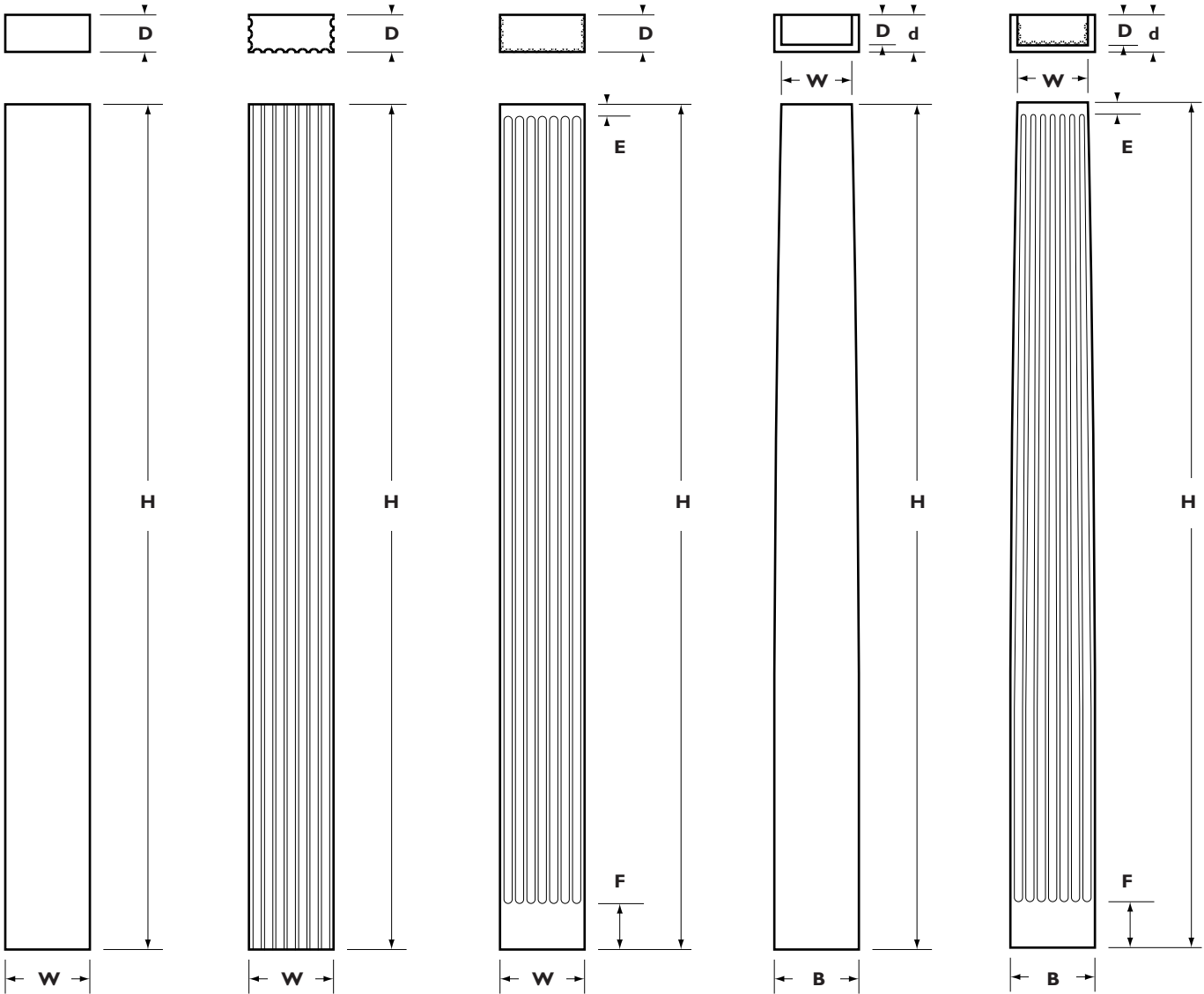

Style 1:
Plain, Straight
Shaft

Style 2:
Fluted, Straight
Shaft

Style 3:
Fluted, Straight
Shaft with
Endflutes

Style 4:
Plain, Entasis
Shaft

Style 5:
Fluted, Entasis
Shaft with
Endflutes

Note: Pilasters of Style 2, 3, or 5 with a depth of less than one-half the pilaster width do not have flutes on the side of the pilaster.

Gypsum Cement Pilaster Shafts

Number	Style	H		W		B		D		d		E		F	
		inch	m	inch	mm	inch	mm	inch	mm	inch	mm	inch	mm	inch	mm
Standard Pilaster Shafts															
6001C	1	94 ¹ / ₂	2.400	6	152			3	76						
6001E	1	105 ³ / ₈	2.677	8	203			4	102						
6001G	1	116 ⁷ / ₈	2.969	10	254			5	127						
6001I	1	116 ³ / ₄	2.965	12	305			6	152						
6002A	2	83 ¹ / ₈	2.111	4	102			2	51						
6102A	2	83 ¹ / ₈	2.111	4	102					³ / ₄	19				
6002B	2	88 ¹ / ₂	2.248	5	127			2 ¹ / ₂	64						
6002C	2	94 ¹ / ₂	2.400	6	152			3	76						
6102C	2	94 ¹ / ₂	2.400	6	152			1 ¹ / ₂	38						
6002D	2	97 ⁷ / ₈	2.486	7	178			3 ¹ / ₂	89						
6002E	2	105 ³ / ₈	2.677	8	203			4	102						
6102E	2	105 ³ / ₈	2.677	8	203			1 ¹ / ₂	38						
6002F	2	110 ³ / ₄	2.813	9	229			4 ¹ / ₂	114						
6002G	2	116 ⁷ / ₈	2.969	10	254			5	127						
6102G	2	116 ⁷ / ₈	2.969	10	254			1 ³ / ₄	45						
6002H	2	116	2.946	11	279			5 ¹ / ₂	140						
6002I	2	116 ³ / ₄	2.965	12	305			6	152						
6003A	3	83 ¹ / ₈	2.111	4	102			2	51			³ / ₄	19	6 ¹ / ₈	156
6003B	3	88 ¹ / ₂	2.248	5	127			2 ¹ / ₂	64			³ / ₄	19	9 ¹ / ₈	232
6003C	3	94 ¹ / ₂	2.400	6	152			3	76			³ / ₄	19	10 ¹ / ₄	260
6103C	3	94 ¹ / ₂	2.400	6	152			1 ¹ / ₂	38			³ / ₄	19	10 ¹ / ₄	260
6003D	3	97 ⁷ / ₈	2.486	7	178			3 ¹ / ₂	89			³ / ₄	19	10 ¹ / ₄	260
6003E	3	105 ³ / ₈	2.677	8	203			4	102			³ / ₄	19	10 ³ / ₄	273
6103E	3	105 ³ / ₈	2.677	8	203			1 ¹ / ₂	38			³ / ₄	19	10 ³ / ₄	273
6003F	3	110 ³ / ₄	2.813	9	229			4 ¹ / ₂	114			³ / ₄	19	10 ³ / ₄	273
6003G	3	116 ⁷ / ₈	2.969	10	254			5	127			³ / ₄	19	11 ³ / ₄	299
6103G	3	116 ⁷ / ₈	2.969	10	254			1 ³ / ₄	45			³ / ₄	19	11 ³ / ₄	299
6003H	3	116	2.946	11	279			5 ¹ / ₂	140			³ / ₄	19	15 ³ / ₈	391
6003I	3	116 ³ / ₄	2.965	12	305			6	152			³ / ₄	19	15 ³ / ₈	391
6004C	4	94 ¹ / ₂	2.400	6	152	7 ¹ / ₂	191	3	76	3 ³ / ₄	95				
6004D	4	97 ⁷ / ₈	2.486	7	178	8 ¹ / ₂	216	3 ¹ / ₂	89	4 ¹ / ₄	108				
6004E	4	105 ³ / ₈	2.677	8	203	10	254	4	102	5	127				
6004G	4	116 ⁷ / ₈	2.969	10	254	12	305	5	127	6	152				
6004I	4	116 ³ / ₄	2.965	12	305	14	356	6	152	7	178				
6005C	5	94 ¹ / ₂	2.400	6	152	7 ¹ / ₂	191	3	76	3 ³ / ₄	95	³ / ₄	19	10 ¹ / ₄	260
6005D	5	97 ⁷ / ₈	2.486	7	178	8 ¹ / ₂	216	3 ¹ / ₂	89	4 ¹ / ₄	108	³ / ₄	19	10 ¹ / ₄	260
6005E	5	105 ³ / ₈	2.677	8	203	10	254	4	102	5	127	³ / ₄	19	10 ³ / ₄	273
6005G	5	116 ⁷ / ₈	2.969	10	254	12	305	5	127	6	152	³ / ₄	19	11 ³ / ₄	299
6005I	5	116 ³ / ₄	2.965	12	305	14	356	6	152	7	178	³ / ₄	19	15 ³ / ₈	391
Non-standard Pilaster Shafts															
3427	3	38 ¹ / ₄	0.972	4 ³ / ₈	111			1	25			³ / ₈	10	³ / ₈	10
6502	3	88 ³ / ₄	2.254	6	152			1 ¹ / ₂	38			³ / ₄	10	7	178
6503	3	90 ¹ / ₂	2.299	6	152			1 ¹ / ₄	32			1 ¹ / ₂	38	15 ⁷ / ₈	403
6506	3	97	2.464	8	203			1 ¹ / ₄	32			1 ³ / ₄	44	16	406
6507	3	91 ³ / ₄	2.330	8	203			1 ³ / ₄	44			³ / ₄	19	1 ¹ / ₂	38
6508	3	80	2.032	9	229			1 ¹ / ₄	32			³ / ₄	19	11 ¹ / ₄	286
6509	3	82 ¹ / ₈	2.086	9	229			1 ¹ / ₂	38			1	25	1	25
6510	3	91 ³ / ₄	2.330	9	229			1 ¹ / ₄	32			1 ¹ / ₂	13	³ / ₄	19
6511	3	80	2.032	10	254			2	51			1 ¹ / ₄	32	1 ³ / ₄	44
6512	3	85 ¹ / ₄	2.165	10 ⁷ / ₈	276			2 ¹ / ₂	64			1	25	1	25
6513	5	95 ³ / ₄	2.432	12	305	14	356	2 ¹ / ₂	64	3	76	⁵ / ₈	16	4 ³ / ₄	121

Installing Gypsum Columns & Pilasters

Installing a Pilaster

Pilasters are usually supplied as three separate pieces: a capital, the pilaster shaft, and a slip on base. The first step in installing a pilaster is to position and fasten a plinth in place. Plinths are usually made of hardwood and act to protect the pilaster from damage from cleaning utensils.

With the plinth in place, the pilaster shaft can be cut to height (at the bottom end). We recommend that it be

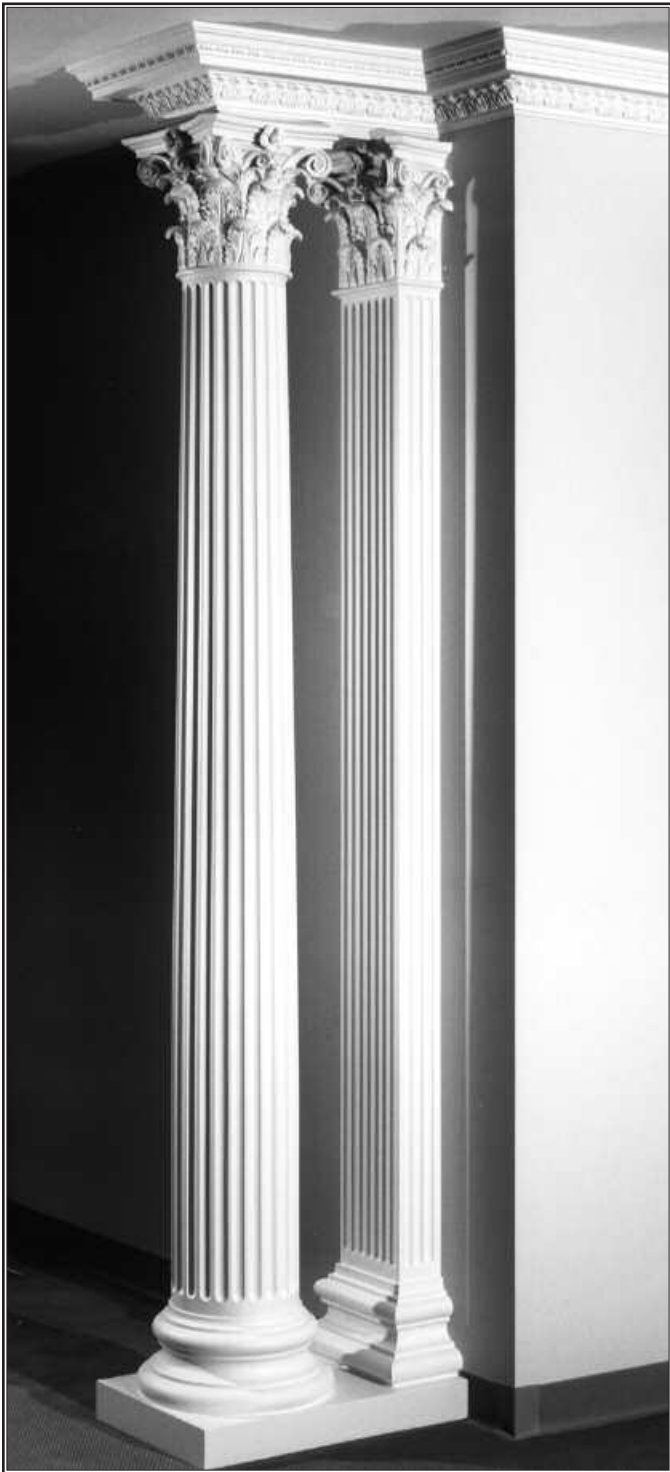

cut $\frac{1}{8}$ " shorter than the measured required height. Do not forget to allow for the height of the capital.

The pilaster shaft and capital are then placed in position. The pilaster can now be plumbed using two thin wedges between the bottom of the pilaster and the plinth. Once they are positioned, outline the capital and pilaster shaft with a pencil so that they can be taken down for the application of adhesive and later be easily repositioned.

Next, holes are drilled in the capital and pilaster shaft for the placement of drywall screws. Two screws per piece are usually sufficient. Screw holes should be countersunk sufficiently so that they can later be easily filled.

A gypsum adhesive, such as Sheetrock 90, made by United States Gypsum Company, is then applied to the back and bottom of the capital and the pilaster shaft. They are then returned to position and screwed in place.

The base can be slipped over the pilaster shaft after trimming the wedges. It is fastened in place with gypsum adhesive.

Once the adhesive has set, a sandable, paintable, non-shrinking filler is used to fill screw holes and blend joints. Pieces can be primed with any drywall primer/sealer and finished as desired with any latex or oil based paint.

Installing a Column

Columns are usually supplied as two separate pieces: a column consisting of a capital attached to a column shaft, and a slip on base. The first step in installing a column is to position and fasten a plinth in place. Plinths are usually made of hardwood and act to protect the column from damage from cleaning utensils.

With the plinth in place, the column shaft can be cut to height (at the bottom end). We recommend that it be cut $\frac{1}{8}$ " shorter than the measured required height.

Before the column can be placed in position, the base must be slipped on over the column shaft (in its proper orientation). The column can then be plumbed using three thin wedges between the bottom of the column and the plinth.

Next, holes are drilled in the capital and base for the placement of drywall screws. Screw holes should be countersunk enough that they can later be easily filled. In the capital, three or four screws should be angled upwards through the abacus of the capital into the ceiling. In the base, three holes should be angled downward into the plinth. A sandable, paintable, non-shrinking filler is used to fill screw holes and blend joints.

One Piece Gypsum Cement Wall Niches

Three one piece complete niches are available ranging in size from a height of 3 feet, 5½ inches to 6 feet, 6 inches.

Each one piece gypsum cement niche includes a base shelf and integral margin. The 771C niche (only) includes a recessed halogen light housing, transformer and lens.

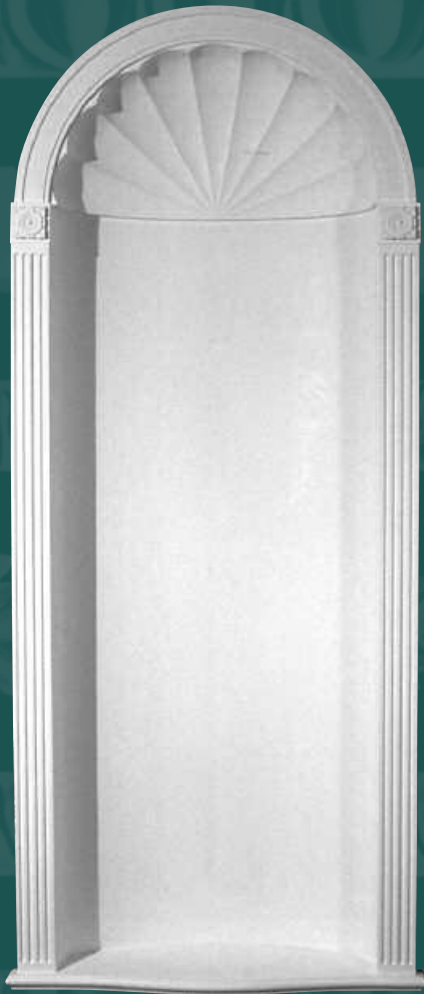

776C Height: 78" 1.98 m
Width: 32 1/8" 816 mm
Framing Depth: 7" 178 mm



771C Height: 55 1/8" 1.40 m
Width: 28 1/4" 718 mm
Framing Depth: 11" 279 mm



775C Height: 41 1/2" 1.05m
Width: 20 3/4" 527 mm
Framing Depth: 6 1/2" 165 mm

Custom Plain Niches

We supply a variety of custom niches in both plain and shell designs. Custom plain niches like the one shown above can be ordered with any internal width up to 4 feet (1.22 m) and any height up to 8 feet (2.44 m) with a depth of up to 2 feet (610 mm).

When ordering a plain niche, you can specify a niche margin (shown on the following page), and whether you require a keystone.

Keystones are available for use with the 3479, 3528, and 3529 margins. Custom plain niches are shipped as an attached plain shell and shaft with separate margin pieces and without a base shelf.

A custom shelf is prohibitively expensive when manufactured in gypsum. We recommend the use of a simple rectangular wood shelf with all custom niches.



Assembled custom plain niche
with keystone & 3479 margin.

Shown with a simple wood shelf (by others)

Custom Gypsum Cement Shell Niches



Assembled custom shell niche using the 771 niche shell, a 48 inch shaft, two 3144 rosette stop blocks and showing a choice of niche margins: 3479 at the right and 3500 at the left.



Niche shell and shaft (attached) as shipped

Custom shell niches are available using the seven shell designs shown on the following page. These niches are supplied as an attached shell and shaft with niche margin pieces and optional rosette stop blocks supplied separately. Custom niches do not include a base shelf. You can specify a shaft length of up to 5 feet (1.52 m).

Niche Margins



3479 Width: 3" 76 mm
Proj: 7/8" 22 mm



3515 Width: 3 1/4" 83 mm
Proj: 1 1/4" 32 mm

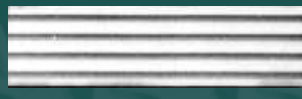

3500 Width: 3" 76 mm
Proj: 7/8" 22 mm



3528 Width: 2 1/16" 52 mm
Proj: 3/4" 19 mm



3529 Width: 2 1/8" 54 mm
Proj: 5/8" 16 mm



3530 Width: 2 7/8" 72 mm
Proj: 5/8" 16 mm

Suitable for niche shell

771
773
774

772

771
774

770

775

776

Niche Rosette Stop Blocks

3144
3 1/4 × 1 in
83 × 25 mm



3140
3 1/2 × 1 3/8 in
89 × 35 mm



Gypsum Cement Niche Shells

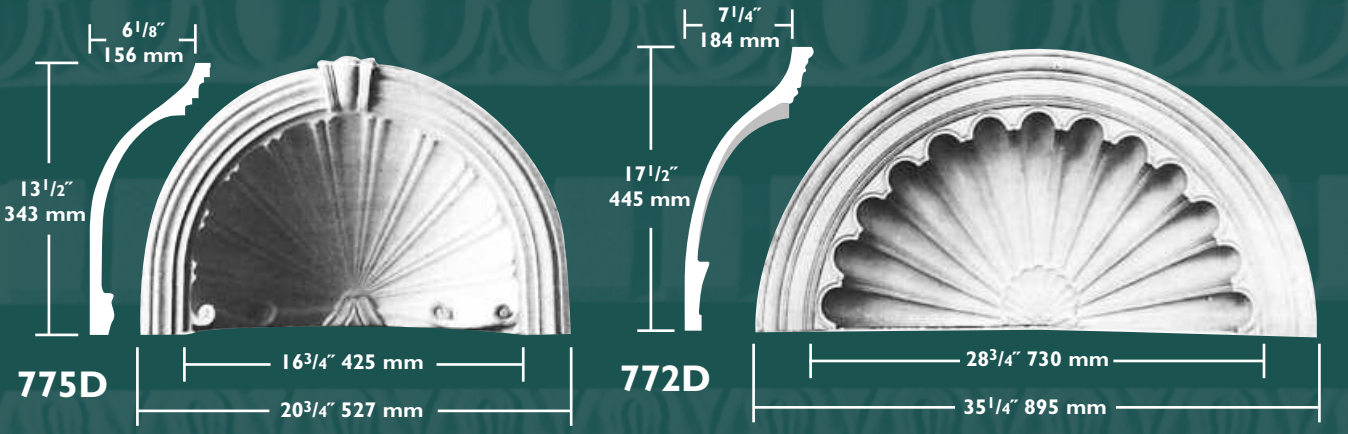
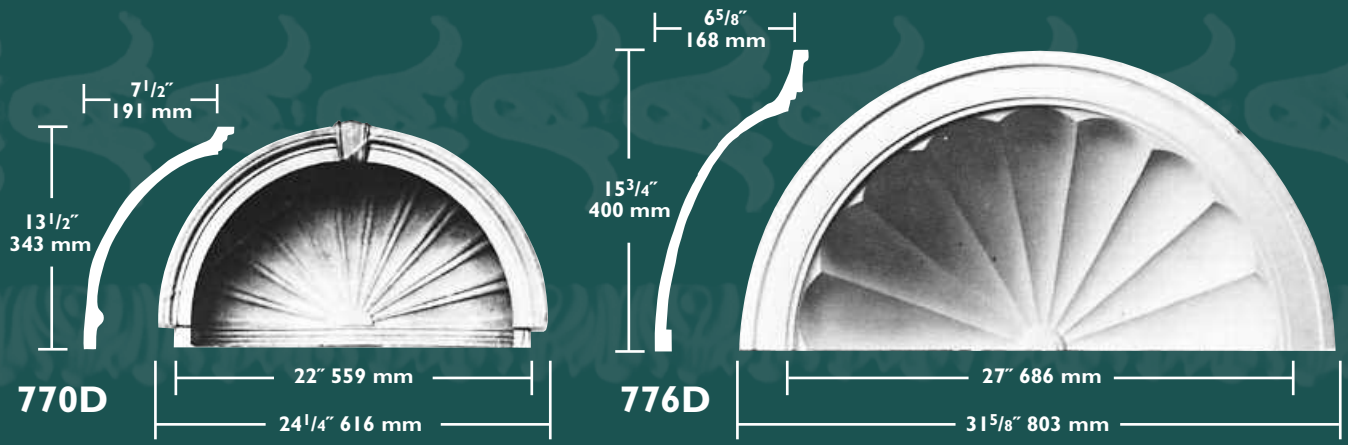

Niche shafts are available to match each shell shown. The shaft to match the 770D shell is part number 770E. The shaft to match the 776D shell is part number 776E, and so on. Niche shafts are available in any length up to 5 feet (1.52 m). When ordered together, the shell and shaft are shipped attached.

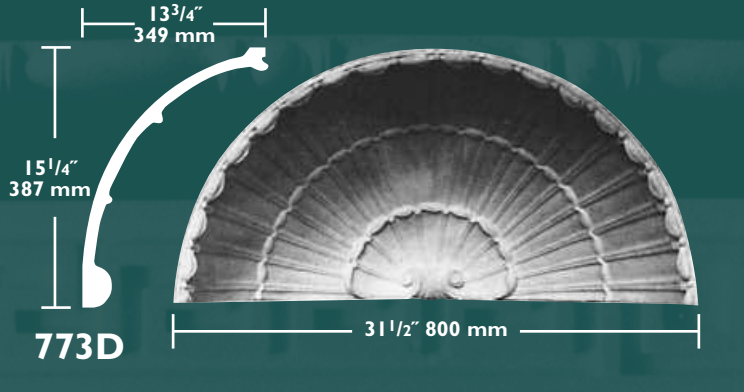
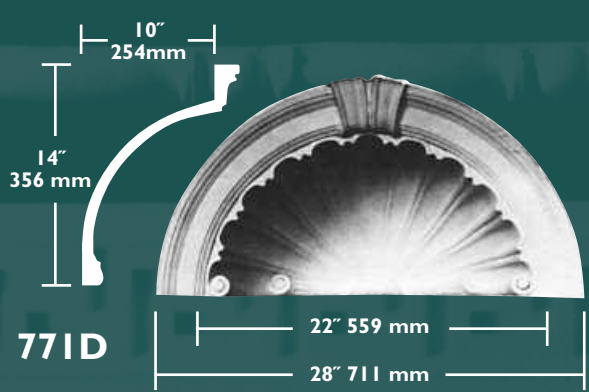
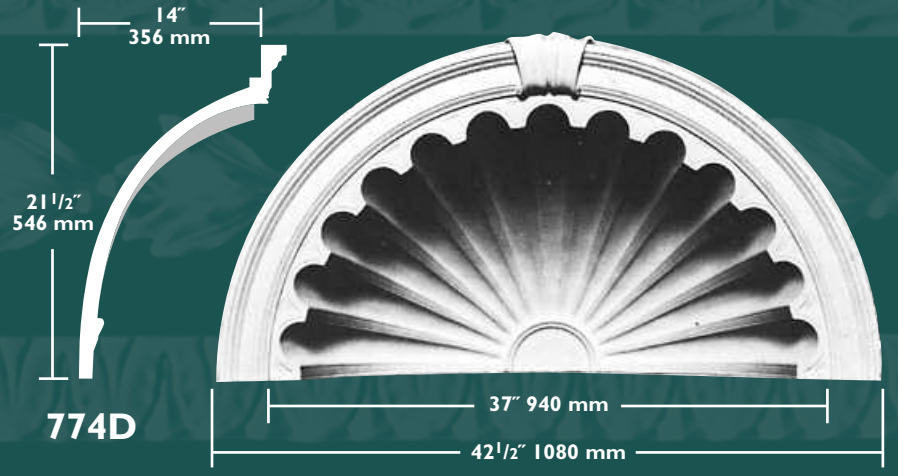

Installing a Gypsum Cement Wall Niche

Niche Planning

All Balmer gypsum niches are designed to be deep enough to hold a vase of flowers or a small sculpture. This depth is usually not available in existing walls. It is therefore usually necessary to design and build a structure to house the niche. The four diagrams at right show options for the design of such structures. In addition to the blocking shown, we recommend that a simple rectangular supporting frame constructed of two by fours be provided beneath the niche.

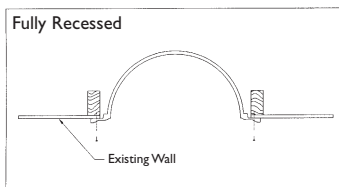
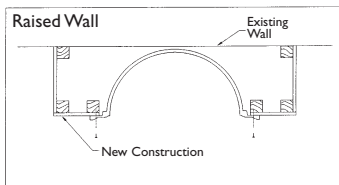
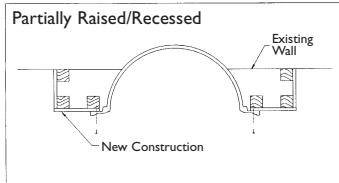
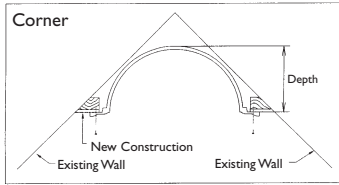

Installation

Once drywall work is completed, you are ready to install the niche itself. First, mark the outline of the recess opening as drawn below. A nail and string can be used as a compass to draw the semicircle at the top. The opening can then be cut using a jig saw or hole saw.

All niches should be fastened in place with Sheetrock 90 adhesive (made by U.S. Gypsum Co.) applied to the back of the niche margin and by countersunk drywall screws. Screws should be installed through the margin through pre-drilled holes. Ensure that the screws penetrate wood blocking or studs to a depth of at least 1 inch.

Custom niches should be additionally screwed in place through pre-drilled holes in the niche shaft into blocking.

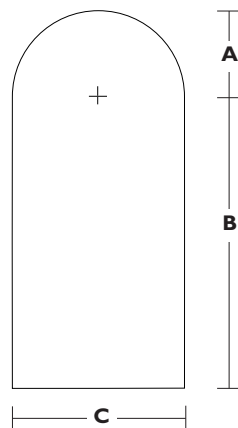

No	A (in)	(mm)	B (in)	(mm)	C (in)	(mm)
771C	12 1/2	318	40 1/2	1029	25	635
775C	9	229	30	762	18	457
776C	13 1/2	343	62 1/2	1588	27	686



On This Page:
custom recessed panels, finished in
gold leaf at the St. Regis Sheraton
Hotel, New York

Gypsum Plaster Panel Mouldings



Gypsum Plaster Panel Mouldings

2289



$2\frac{3}{4} \times \frac{3}{4} \times 74\frac{3}{4}$ "
70 × 19 × 1899 mm

1563



$2\frac{3}{4} \times 1 \times 72$ "
70 × 25 × 1829 mm

8001



$2\frac{3}{8} \times 1\frac{5}{8} \times 81\frac{3}{4}$ "
60 × 41 × 2076 mm

1560



$2\frac{3}{4} \times \frac{5}{8} \times 72\frac{1}{2}$ "
70 × 16 × 1842 mm

8002



$1\frac{3}{4} \times 1\frac{1}{8} \times 68\frac{1}{8}$ "
44 × 29 × 1730 mm

2094



$2 \times \frac{3}{4} \times 81$ "
51 × 18 × 2057 mm

8003



$2 \times 1\frac{3}{4} \times 52$ "
51 × 44 × 1321 mm

2785



$1\frac{7}{8} \times \frac{5}{8} \times 71$ "
48 × 16 × 1803 mm

2262



$1\frac{3}{8} \times \frac{5}{8} \times 67\frac{1}{2}$ "
35 × 16 × 1715 mm

3475



$1\frac{3}{8} \times \frac{1}{2}$ "
35 × 13 mm

1277



$1\frac{3}{4} \times \frac{5}{8} \times 71$ "
44 × 16 × 1803 mm

1499



$1\frac{1}{2} \times \frac{1}{2}$ "
38 × 13 mm

1150



$1\frac{5}{8} \times \frac{3}{4} \times 52$ "
41 × 19 × 1320 mm

660



$1 \times \frac{1}{2} \times 62$ "
25 × 13 × 1575 mm

2028



$2 \times \frac{1}{2} \times 66\frac{1}{2}$ "
51 × 13 × 1689 mm

3179



$1 \times \frac{1}{2}$ "
24 × 13 mm

3180



$1 \times \frac{1}{4} \times 72$ "
25 × 6 × 1829 mm

1516



$1\frac{1}{4} \times \frac{3}{4} \times 66$ "
32 × 19 × 1676 mm

2317



$\frac{7}{8} \times \frac{1}{4} \times 62\frac{1}{2}$ in
22 × 6 × 1588 mm

1296



$1\frac{1}{8} \times \frac{3}{8} \times 31$ "

29 × 10 × 762 mm

2770



$6\frac{1}{2} \times \frac{7}{8} \times 73\frac{1}{2}$ "

165 × 22 × 1867 mm

2093



$1\frac{1}{2} \times \frac{5}{8} \times 90$ "

38 × 16 × 2286 mm

2771



$5\frac{1}{16} \times \frac{7}{8} \times 64\frac{1}{4}$ "

145 × 22 × 1632 mm

2089



$1\frac{1}{2} \times \frac{5}{8} \times 91$ "

38 × 16 × 2311 mm

2776



$3\frac{1}{8} \times \frac{9}{16} \times 72\frac{1}{2}$ "

79 × 14 × 1842 mm

2092



$2 \times \frac{3}{4} \times 81$ "

51 × 19 × 2057 mm

3751



$3\frac{7}{16} \times \frac{9}{16} \times 84$ "

87 × 14 × 2134 mm

3196



$2 \times 1 \times 72\frac{3}{4}$ "

51 × 25 × 1848 mm

902



$4\frac{1}{4} \times 2\frac{1}{8} \times 67\frac{3}{4}$ "

108 × 54 × 1721 mm

Gypsum Plaster Panel Mouldings

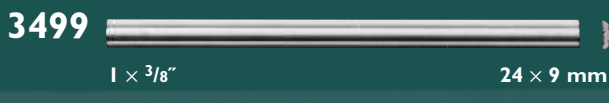
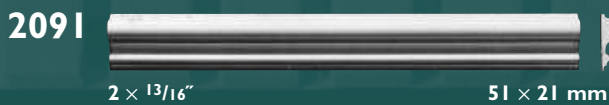

*- Supplied on a solid background to prevent breakage.

Mouldings whose lengths are not shown are available in either 6 ft (1.83 m) or 7 ft 8 in (2.34 m) lengths. Please specify your requirement when ordering.

Gypsum Plaster Panel Moulding Corners

1759 1563 1765 1766 3192 1560 1499 3294 1763 1764 1767 1769 1768 1500 660 1760 1761 1757 2263 2262 548 1516 2263A 2262 1499 2159 1499A

Panel Moulding Corners							
Number	Width		Height		Projection		
	inch	mm	inch	mm	inch	mm	
548	8	203	10 1/2	767	3/4	19	
1499A	9	229	1 1/2	38	1/2	13	
1757	13	330	8	302	5/8	16	
1759*	15 1/2	394	15 1/2	394	1	25	
1760	6 3/4	171	6	152	1 1/8	29	
1761	7	178	7	178	1 3/8	35	
1763	8 1/2	216	6 1/2	165	5/8	16	
1764*	9 1/2	241	9 1/2	241	3/4	19	
1765	18	457	10 1/2	267	5/8	16	
1766	8	203	6	152	5/8	16	
1767	4 1/2	114	4 1/2	114	5/8	16	
1768	4 1/2	114	4 1/2	114	5/8	16	
1769	9 1/2	241	8 1/2	216	3/4	19	
2159	7	178	3	76	3/4	19	
2263*	8	203	8	203	3/4	19	
2263A*	8	203	8	203	3/4	19	
3192*	8 3/4	222	8 3/4	222	1	25	
3294	13 1/2	343	14 1/2	368	3/4	19	

*- Supplied on a solid background to prevent breakage.

Gypsum Plaster Central Features

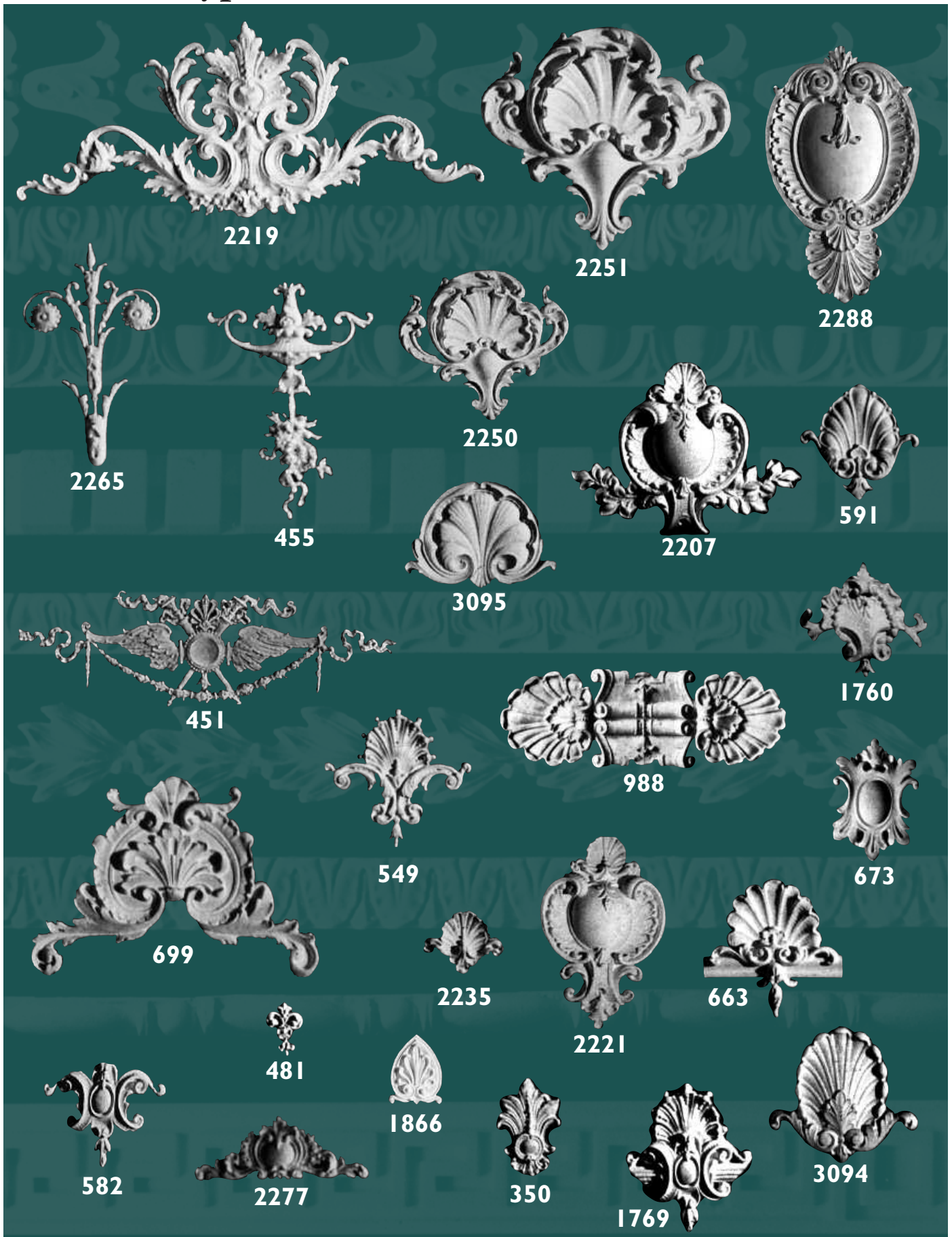

Gypsum Plaster Central Features

Central Features						
Number	Width		Height		Projection	
	inch	mm	inch	mm	inch	mm
300	21	533	14 1/2	368	1	25
350	3	76	5 1/2	140	3/4	19
451*	34	864	12	305	3/4	19
455	13 1/2	343	19	483	3/4	19
481	2	51	2 1/2	64	1/4	6
549	8	203	8	203	1/2	13
555	9 1/2	241	4	102	1/2	13
582	7	178	6	152	3/4	19
591	6 1/2	165	6 1/2	165	1/2	13
593	14	356	5 1/2	140	1/2	13
655	8	203	3 1/2	89	1/2	13
663	7 1/2	191	7 1/2	191	3/4	19
673	4 1/2	114	6	152	3/4	19
692	5 1/2	140	7 1/2	191	1/2	13
699	15	381	9 1/2	241	3/4	19
700	20	508	10 1/2	267	1/2	13
988	31	787	10	254	3/4	19
999	8 1/2	216	4	102	1/4	6
1071	11 1/2	292	3 1/2	89	1/4	6
1401	7 1/2	191	17 1/4	438	1/2	13
1760	7	178	5	127	1	25
1769	7	178	9	229	1/2	13
1865	9	229	4 1/2	114	1/2	13
1866	3 1/4	83	4 1/4	108	1/2	13
2161	8	203	12	305	1/2	13
2172	8 1/2	216	11	279	1/2	13
2207	15	381	11	279	1 1/4	32
2219*	38	965	16	406	1	25
2221	8	203	12 1/2	318	1 1/4	32
2227	12	305	15	381	2	51
2235	4 1/2	114	2 1/2	64	1/2	13
2250*	11	279	9 1/2	241	1 1/4	32
2251	16	406	13 1/2	343	2	51
2265*	11	279	17 1/2	445	1/2	13
2277	14	356	5	127	3/4	19
2288	14	356	23 1/4	591	1 1/4	32
3065	5 1/2	140	4	102	3/4	19
3094	8 1/2	216	9 1/2	241	3/4	19
3095	8	203	6	152	3/4	19

*- Supplied on a solid background to prevent breakage.

Gypsum Plaster Ornaments

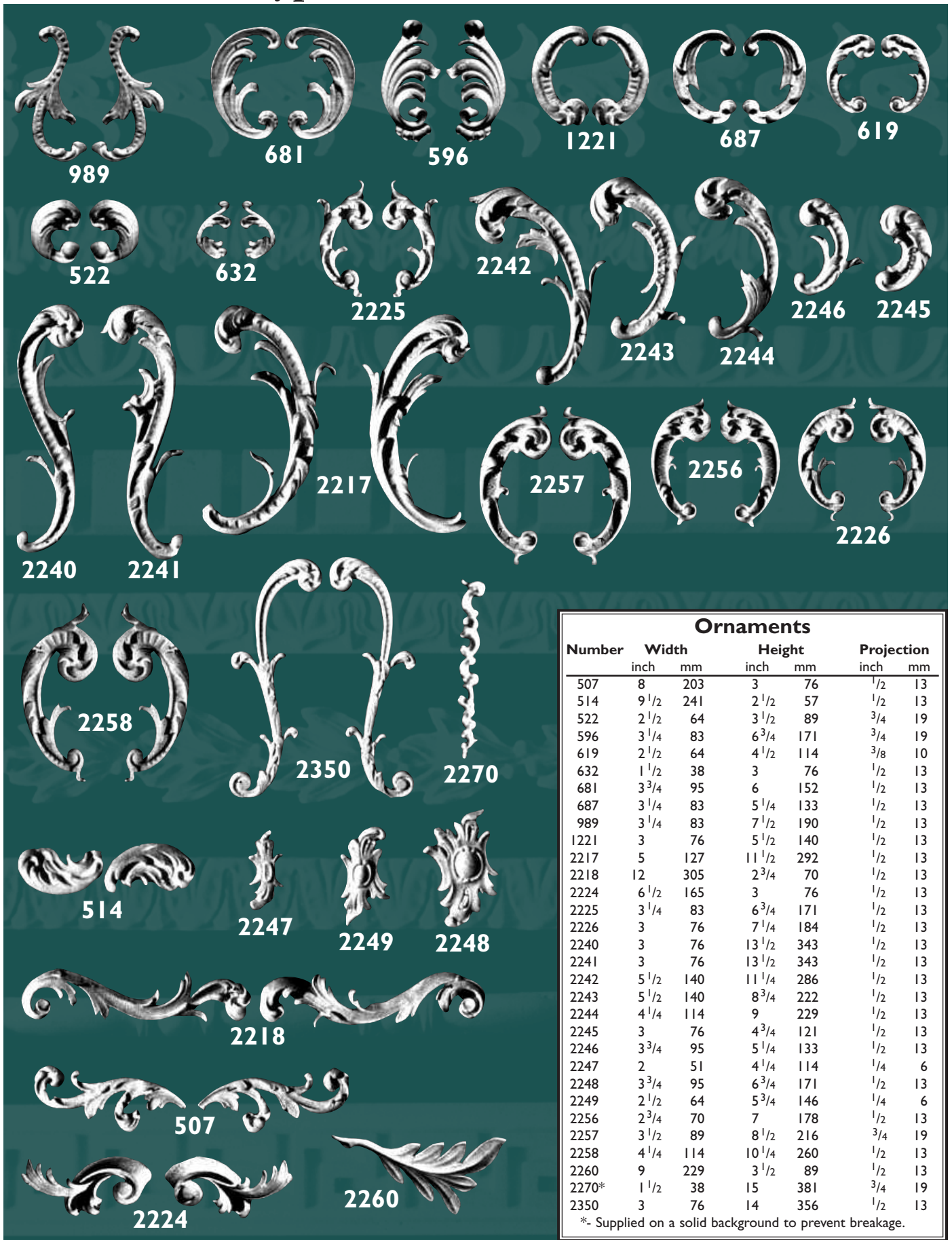

Number	Width		Height		Projection	
	inch	mm	inch	mm	inch	mm
507	8	203	3	76	1/2	13
514	9 1/2	241	2 1/2	57	1/2	13
522	2 1/2	64	3 1/2	89	3/4	19
596	3 1/4	83	6 3/4	171	3/4	19
619	2 1/2	64	4 1/2	114	3/8	10
632	1 1/2	38	3	76	1/2	13
681	3 3/4	95	6	152	1/2	13
687	3 1/4	83	5 1/4	133	1/2	13
989	3 1/4	83	7 1/2	190	1/2	13
1221	3	76	5 1/2	140	1/2	13
2217	5	127	11 1/2	292	1/2	13
2218	12	305	2 3/4	70	1/2	13
2224	6 1/2	165	3	76	1/2	13
2225	3 1/4	83	6 3/4	171	1/2	13
2226	3	76	7 1/4	184	1/2	13
2240	3	76	13 1/2	343	1/2	13
2241	3	76	13 1/2	343	1/2	13
2242	5 1/2	140	11 1/4	286	1/2	13
2243	5 1/2	140	8 3/4	222	1/2	13
2244	4 1/4	114	9	229	1/2	13
2245	3	76	4 3/4	121	1/2	13
2246	3 3/4	95	5 1/4	133	1/2	13
2247	2	51	4 1/4	114	1/4	6
2248	3 3/4	95	6 3/4	171	1/2	13
2249	2 1/2	64	5 3/4	146	1/4	6
2256	2 3/4	70	7	178	1/2	13
2257	3 1/2	89	8 1/2	216	3/4	19
2258	4 1/4	114	10 1/4	260	1/2	13
2260	9	229	3 1/2	89	1/2	13
2270*	1 1/2	38	15	381	3/4	19
2350	3	76	14	356	1/2	13

*- Supplied on a solid background to prevent breakage.

Plaster Brackets & Sconces



Gypsum Plaster Brackets



Number	Max. Width		Nom. Width*		Height		Projection		Number	Max. Width		Nom. Width*		Height		Projection	
	inch	mm	inch	mm	inch	mm	inch	mm		inch	mm	inch	mm	inch	mm	inch	mm
101	7 ⁵ / ₈	194	6	152	11 ⁵ / ₁₆	287	16 ⁷ / ₈	429	126	13 ⁷ / ₈	352	12 ⁵ / ₈	321	17 ³ / ₈	441	20 ⁷ / ₁₆	519
102	12 ¹³ / ₁₆	325	11 ⁹ / ₁₆	302	8 ⁵ / ₈	219	10	254	146	13 ⁷ / ₁₆	341	11 ⁷ / ₈	302	15 ¹ / ₄	387	15 ³ / ₄	400
105	7 ⁵ / ₈	194	8 ¹³ / ₁₆	224	28 ¹¹ / ₁₆	729	12 ³ / ₈	314	2408	6 ¹ / ₂	165	6	152	11 ¹ / ₂	292	5 ¹¹ / ₁₆	144
107	16 ⁷ / ₈	429	13 ¹ / ₁₆	332	17 ¹ / ₈	435	10 ¹ / ₄	260	3214	6 ⁵ / ₁₆	160	5 ⁵ / ₁₆	135	16	406	8	203
110	11 ⁷ / ₈	302	9 ¹⁵ / ₁₆	252	17 ¹ / ₂	445	7 ³ / ₁₆	183	3218	7 ¹ / ₁₆	179	4 ⁵ / ₈	117	13 ⁹ / ₁₆	344	4 ⁵ / ₈	117
119	10 ¹ / ₁₆	256	7 ¹¹ / ₁₆	221	15 ¹¹ / ₁₆	398	6	152	8947	11 ⁵ / ₁₆	303	9 ⁹ / ₁₆	243	20 ¹ / ₈	511	6 ⁷ / ₁₆	164

* Nominal Width is the width of the beam which the bracket ideally suits.

Gypsum Plaster Brackets



163



148



131



141



162



8945



116



3376



134



8940



161



117



160



151



118



3217



165



115

Number	Max. Width		Nom. Width*		Height		Projection	
	inch	mm	inch	mm	inch	mm	inch	mm
115	8 ⁵ / ₈	219	5 ¹⁵ / ₁₆	151	11 1/8	283	4 ³ / ₄	121
116	9 ⁵ / ₁₆	237	7 ⁹ / ₁₆	192	10 1/4	260	3 ³ / ₈	86
117	6 1/4	159	5 ⁷ / ₈	149	5 ⁷ / ₈	149	4 1/2	114
118	8 ⁷ / ₁₆	214	8 ⁷ / ₁₆	214	6 ³ / ₈	162	3 ¹¹ / ₁₆	94
131	8 ¹ / ₈	206	6 ¹⁵ / ₁₆	176	13 1/2	343	4	102
134	11 ⁷ / ₁₆	291	10 ¹¹ / ₁₆	271	8 1/8	206	10 ³ / ₁₆	259
141	7 ¹³ / ₁₆	198	6 ⁷ / ₁₆	164	13 1/4	337	6 ¹³ / ₁₆	173
148	7 ⁵ / ₁₆	186	7 ⁵ / ₁₆	186	13 ³ / ₈	340	4 1/4	108
151	6 ⁵ / ₁₆	160	5 ⁷ / ₁₆	138	4 ⁵ / ₁₆	109	2 ¹⁵ / ₁₆	75

Number	Max. Width		Nom. Width*		Height		Projection	
	inch	mm	inch	mm	inch	mm	inch	mm
160	3 ⁷ / ₁₆	87	3 ¹ / ₁₆	78	5 ³ / ₈	137	3 ¹⁵ / ₁₆	100
161	5 1/4	133	5	127	7 ⁷ / ₈	200	3 1/8	79
162	12	305	10 ³ / ₈	264	17	432	9 ¹³ / ₁₆	249
163	12 ³ / ₈	314	12 ³ / ₈	314	15 1/4	387	5	127
165	5 ⁷ / ₈	149	4 ¹³ / ₁₆	122	7 ⁷ / ₁₆	189	3 1/16	78
3217	5 1/2	140	5 ³ / ₈	137	6 1/8	156	3 ¹¹ / ₁₆	94
3376	12 ³ / ₄	324	10 ⁵ / ₁₆	262	13 1/8	333	5 ⁹ / ₁₆	141
8940	5 1/4	133	4 ⁷ / ₈	124	12	305	4 1/2	114
8945	12 ³ / ₄	324	4	102	13	330	5 1/2	14

* Nominal Width is the width of the beam which the bracket ideally suits.

Gypsum Plaster Brackets

Number	Max. Width		Nom. Width*		Height		Projection	
	inch	mm	inch	mm	inch	mm	inch	mm
106	18 ¹³ / ₁₆	478	17 ¹ / ₂	445	7 ¹ / ₄	184	8 ³ / ₄	222
108	7 ¹ / ₄	184	5 ¹¹ / ₁₆	144	8 ⁵ / ₈	219	6 ⁵ / ₁₆	160
114	14 ³ / ₈	365	11 ³ / ₄	298	12 ¹ / ₂	318	6 ¹ / ₈	156
123	17 ¹ / ₈	435	13 ³ / ₄	349	10 ⁵ / ₈	270	16	406
177	4 ⁵ / ₈	117	4	102	10 ⁹ / ₁₆	268	5	127
3215	4 ³ / ₁₆	106	3 ⁹ / ₁₆	90	19 ³ / ₁₆	467	4 ¹ / ₈	105
8936	5 ⁷ / ₈	149	4 ⁹ / ₁₆	116	12 ⁹ / ₁₆	319	14 ¹ / ₁₆	357
8937	5 ⁹ / ₁₆	141	5	127	19 ¹⁵ / ₁₆	506	6 ¹ / ₈	156
8938	5 ¹ / ₄	133	4 ³ / ₄	121	13 ⁷ / ₈	352	3 ¹ / ₂	89
8939	4 ¹ / ₂	114	4 ¹ / ₂	114	28 ⁵ / ₈	727	4 ⁵ / ₁₆	110
8941	13 ⁹ / ₁₆	344	11 ¹ / ₄	286	18 ⁵ / ₁₆	465	6 ³ / ₄	171
8942	11	279	8 ¹ / ₂	216	8 ³ / ₈	213	20 ¹ / ₈	511
8943	14 ⁷ / ₈	378	12 ⁷ / ₁₆	316	12 ³ / ₁₆	310	5 ¹¹ / ₁₆	144
8944	8 ³ / ₄	222	6 ⁵ / ₁₆	160	30 ³ / ₈	772	7	178

* Nominal Width is the width of the beam which the bracket ideally suits.

Gypsum Plaster Brackets



129

136

124

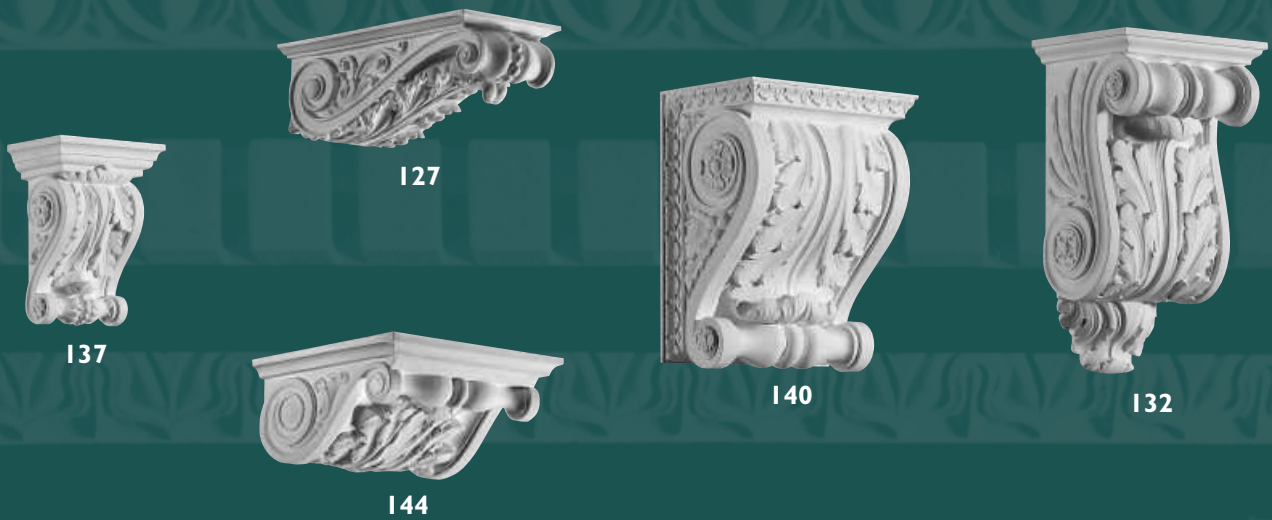

137

127

140

132

144



150

142

152

135

Number	Max. Width		Nom. Width*		Height		Projection	
	inch	mm	inch	mm	inch	mm	inch	mm
124	13 ³ / ₈	340	12 ⁵ / ₈	321	8 ¹ / ₂	216	16 ⁹ / ₁₆	421
127	6 ⁵ / ₈	168	5 ¹ / ₄	133	5 ¹ / ₄	133	14 ³ / ₄	375
129	10	254	8 ³ / ₈	213	22 ¹¹ / ₁₆	576	11 ³ / ₁₆	284
132	9 ³ / ₄	248	9	229	17 ¹ / ₈	435	7 ³ / ₈	187
135	7 ¹ / ₁₆	179	5 ⁵ / ₈	143	8 ⁷ / ₈	225	4 ⁷ / ₁₆	113
136	11 ⁵ / ₈	295	10 ¹ / ₄	260	14 ¹ / ₂	368	6 ³ / ₈	162
137	7 ¹ / ₈	181	5 ⁵ / ₈	143	9 ¹ / ₄	235	4 ³ / ₁₆	106
140	11 ⁵ / ₁₆	287	10 ⁷ / ₈	276	14 ¹ / ₄	362	7 ⁵ / ₁₆	186
142	11	279	10 ³ / ₁₆	259	8 ¹ / ₂	216	15 ⁵ / ₁₆	389
144	11 ⁷ / ₈	302	10 ⁵ / ₈	270	5 ⁷ / ₁₆	138	10 ⁹ / ₁₆	268
150	10 ¹¹ / ₁₆	271	8 ¹³ / ₁₆	224	16 ¹ / ₄	413	6 ³ / ₁₆	157
152	14 ¹ / ₁₆	357	13	330	9	229	11 ¹³ / ₁₆	300

* Nominal Width is the width of the beam which the bracket ideally suits.

Gypsum Plaster Brackets



Number	Max. Width		Nom. Width*		Height		Projection		Number	Max. Width		Nom. Width*		Height		Projection	
	inch	mm	inch	mm	inch	mm	inch	mm		inch	mm	inch	mm	inch	mm	inch	mm
130	12 ³ / ₈	314	10 ³ / ₄	273	17 ¹ / ₄	438	3 ³ / ₄	95	188	12 ¹ / ₁₆	306	10 ⁹ / ₁₆	268	18 ¹ / ₂	470	10 ¹ / ₄	260
139	7 ⁷ / ₈	200	6 ⁷ / ₁₆	164	13 ³ / ₄	349	4	102	2402	7	178	5 ⁷ / ₁₆	138	7 ³ / ₄	197	2 ³ / ₈	60
143	9 ³ / ₈	238	7 ¹¹ / ₁₆	195	8 ¹ / ₄	210	4 ¹ / ₄	108	2403	5 ¹ / ₁₆	129	4 ¹ / ₂	114	6 ¹³ / ₁₆	173	2	51
153	5 ¹ / ₁₆	129	4 ¹ / ₁₆	103	4	102	3 ⁵ / ₈	92	2999	15	381	14 ⁵ / ₁₆	364	8 ⁷ / ₁₆	214	20 ¹¹ / ₁₆	525
156	8 ¹ / ₁₆	205	7 ¹ / ₈	181	6 ¹ / ₂	165	7 ⁵ / ₁₆	186	3206	14 ⁷ / ₈	378	13	330	17 ⁹ / ₁₆	446	7 ⁹ / ₁₆	192
158	5 ³ / ₁₆	132	4 ¹ / ₂	114	4 ⁹ / ₁₆	116	7 ⁵ / ₁₆	186	3216	6 ⁷ / ₈	175	6 ⁵ / ₈	168	8 ⁹ / ₁₆	217	3 ⁷ / ₁₆	87
181	4 ⁷ / ₈	124	4 ¹³ / ₁₆	122	5 ⁷ / ₈	149	5 ¹ / ₂	140	3220	30	762	28 ¹ / ₂	724	6 ¹ / ₄	159	3 ⁵ / ₈	92
183	10 ⁹ / ₁₆	268	8 ⁵ / ₈	219	8 ¹ / ₈	206	3 ⁷ / ₈	98	3223	6 ⁷ / ₁₆	164	6 ¹ / ₈	156	11 ¹ / ₄	286	3 ³ / ₄	95
187	13 ¹¹ / ₁₆	348	11 ¹ / ₄	286	17 ¹ / ₄	438	4 ⁹ / ₁₆	116	8946	5	127	4 ¹³ / ₁₆	122	22 ¹ / ₂	572	5 ³ / ₈	137

* Nominal Width is the width of the beam which the bracket ideally suits.

Gypsum Sconces & Table Brackets



2842



2416



2831



2836

The 3540 Gryphon Bracket is suited for use as a table support. Two gryphons and the 3540C frieze band can be used to support a parson's table. Four gryphons and the 3540A square pedestal, or three gryphons and the 3540B triangular pedestal can be used to support table surfaces of other shapes.



3540



3540A



3540B



2970

The 2970 Lion Bracket is suited for use as a console bracket (singly or in pairs). A pair can also be used with a plain mantle shelf as a fireplace surround.



3540C-PL

No.	Width		Height		Projection	
	inch	mm	inch	mm	inch	mm
2416	17	432	18	457	10	254
2831	18	457	7	178	6	152
2836	16	406	13	330	5	127
2842	20	508	14 1/2	368	9	229
2970	9	289	21	533	12	305
3540	6	152	28 1/2	724	13	330
3540A	6 3/4	171	28 1/2	724	6 3/4	171
3540B	7 1/2	191	28 1/2	724	6 1/2	165
3540C*	35 1/4	895	6 1/8	156	1 1/2	38

*- The 3540C-PL is made of primed polyurethane